

PART : MATHEMATICS

1 Let $A = \{x \in \mathbb{R} : |x + 1| < 2\}$ and $B = \{x \in \mathbb{R} : |x - 1| \geq 2\}$. Then which one the following statements is NOT true?

- (A) $A - B = (-1, 1)$ (B) $B - A = \mathbb{R} - (-3, 1)$
 (C) $A \cap B = (-3, -1]$ (D) $A \cup B = \mathbb{R} - [1, 3)$

NTA Ans. (B)

Reso Ans. (B)

Sol. $|x + 1| < 2 \Rightarrow -2 < x + 1 < 2 \Rightarrow x \in (-3, 1) = A$

$$|x - 1| \geq 2 \Rightarrow x - 1 \leq -2 \cup x - 1 \geq 2$$

$$\Rightarrow x \leq -1 \cup x \geq 3 \Rightarrow x \in (-\infty, -1] \cup [3, \infty)$$

$$A = (-3, 1) \quad B = (-\infty, -1] \cup [3, \infty)$$

$$A' = (-\infty, -3] \cup [1, \infty) \quad B' = (-1, 3)$$

$$A - B = A \cap B' = (-1, 1)$$

$$B - A = A' \cap B = (-\infty, -3] \cup [3, \infty)$$

$$A \cup B = (-\infty, 1) \cup [3, \infty)$$

$$A \cap B = (-3, -1]$$

2 Let $a, b \in \mathbb{R}$ be such that the equation $ax^2 - 2bx + 15 = 0$ has a repeated root α . If α and β are the roots of the equation $x^2 - 2bx + 21 = 0$, then $\alpha^2 + \beta^2$ is equal to:

- (A) 37 (B) 58 (C) 68 (D) 92

NTA Ans. (B)

Reso Ans. (B)

Sol. Equation

$$ax^2 - 2bx + 15 = 0 \begin{cases} \alpha \\ \alpha \end{cases}$$

Sum of root $\alpha + \alpha = \frac{2b}{a} \Rightarrow \alpha = b/a$

Product of root $\alpha \cdot \alpha = \frac{15}{a} \Rightarrow a = \frac{15}{\alpha^2}$

since roots are repeated $\Rightarrow D = 0$

$$\Rightarrow 4b^2 - 4a \cdot 15 = 0 \Rightarrow b^2 = 15a = \frac{15^2}{\alpha^2} \Rightarrow b = \pm \frac{15}{\alpha}$$

Equation

$$x^2 - 2bx + 21 = 0 \begin{cases} \alpha \\ \beta \end{cases}$$

Sum of root $\alpha + \beta = 2b,$

Product of root $\alpha\beta = 21$

$$\alpha + \frac{21}{\alpha} = 2\left(\frac{15}{\alpha}\right) \Rightarrow \alpha^2 = 9 \Rightarrow \alpha = \pm 3$$

$$\Rightarrow \beta = \pm 7$$

The value of

$$\alpha^2 + \beta^2 = 9 + 49 = 58$$

Resonance Eduventures Ltd.

Reg. Office & Corp. Office : CG Tower, A-46 & 52, IPIA, Near City Mall, Jhalawar Road, Kota (Raj.) - 324005

Ph. No.: +91-744-2777777, 2777700 | FAX No. : +91-022-39167222

To Know more : sms RESO at 56677 | Website : www.resonance.ac.in | E-mail : contact@resonance.ac.in | CIN : U80302RJ2007PLC024029

Toll Free : 1800 258 5555 | 7340010333 | facebook.com/ResonanceEdu | twitter.com/ResonanceEdu | www.youtube.com/resowatch | blog.resonance.ac.in

3 Let z_1 and z_2 be two complex numbers such that $\bar{z}_1 = iz_2$ and $\arg\left(\frac{z_1}{z_2}\right) = \pi$. Then

Question:

A $\arg z_2 = \frac{\pi}{4}$

B $\arg z_2 = -\frac{3\pi}{4}$

C $\arg z_1 = \frac{\pi}{4}$

D $\arg z_1 = -\frac{3\pi}{4}$

NTA Ans. (C)

Reso Ans. (C)

Sol.

$$\arg\left(\frac{z_1}{z_2}\right) = \pi \Rightarrow \arg z_1 - \arg z_2 = \pi$$

$$\Rightarrow \arg z_1 + \arg z_2 = \pi \quad \dots\dots(1)$$

$$\because \bar{z}_1 = iz_2 \Rightarrow z_1 = -iz_2$$

$$\Rightarrow \arg z_1 = \arg(-iz_2)$$

$$\Rightarrow \arg z_1 = \arg(-i) + \arg z_2$$

$$\Rightarrow \arg z_1 - \arg z_2 = -\frac{\pi}{2} \quad \dots\dots(2)$$

$$\text{from (1) and (2) } \arg z_1 = \frac{\pi}{4} \text{ and } \arg z_2 = \frac{3\pi}{4}$$

4 The system of equations

$$-kx + 3y - 14z = 25$$

$$-15x + 4y - kz = 3$$

$$-4x + y + 3z = 4$$

Question: is consistent for all k in the set

A \mathbb{R}

B $\mathbb{R} - \{-11, 13\}$

C $\mathbb{R} - \{13\}$

D $\mathbb{R} - \{-11, 11\}$

Resonance Eduventures Ltd.

Reg. Office & Corp. Office : CG Tower, A-46 & 52, IPIA, Near City Mall, Jhalawar Road, Kota (Raj.) - 324005

Ph. No.: +91-744-2777777, 2777700 | FAX No. : +91-022-39167222

To Know more : sms RESO at 56677 | Website : www.resonance.ac.in | E-mail : contact@resonance.ac.in | CIN : U80302RJ2007PLC024029

Toll Free : 1800 258 5555  7340010333  facebook.com/ResonanceEdu  twitter.com/ResonanceEdu  www.youtube.com/resowatch  blog.resonance.ac.in

NTA Ans. (D)

Reso Ans. (D)

Sol.
$$\begin{vmatrix} -k & 3 & -14 \\ -15 & 4 & -k \\ -4 & 1 & 3 \end{vmatrix} \neq 0$$

$$-k^2 + 121 \neq 0 \Rightarrow k \neq \pm 11$$

$$R - \{-11, 11\}$$

5
$$\lim_{x \rightarrow \frac{\pi}{2}} \left(\tan^2 x \left((2 \sin^2 x + 3 \sin x + 4)^{\frac{1}{2}} - (\sin^2 x + 6 \sin x + 2)^{\frac{1}{2}} \right) \right)$$
 is equal to

- (A) $\frac{1}{12}$ (B) $-\frac{1}{18}$ (C) $-\frac{1}{12}$ (D) $\frac{1}{6}$

NTA Ans. (A)

Reso Ans. (A)

6 The area of the region enclosed between the parabolas $y^2 = 2x - 1$ and $y^2 = 4x - 3$ is

- (A) $\frac{1}{3}$ (B) $\frac{1}{6}$ (C) $\frac{2}{3}$ (D) $\frac{3}{4}$

NTA Ans. (A)

Reso Ans. (A)

Sol.

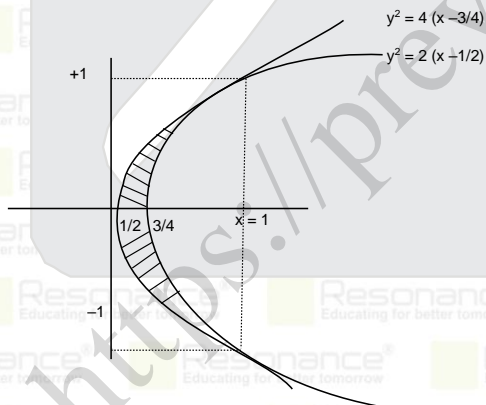

When $y^2 = 2x - 1$

$y^2 = 4x - 3$

$4x - 3 = 2x - 1$

$x = 1, y = \pm 1$

Point of intersection are $(1, 1), (1, -1)$

Resonance Eduventures Ltd.

Reg. Office & Corp. Office : CG Tower, A-46 & 52, IPIA, Near City Mall, Jhalawar Road, Kota (Raj.) - 324005

Ph. No.: +91-744-2777777, 2777700 | FAX No. : +91-022-39167222

To Know more : sms RESO at 56677 | Website : www.resonance.ac.in | E-mail : contact@resonance.ac.in | CIN : U80302RJ2007PLC024029

Toll Free : 1800 258 5555 | 7340010333 | facebook.com/ResonanceEdu | twitter.com/ResonanceEdu | www.youtube.com/resowatch | blog.resonance.ac.in

$$\begin{aligned} \text{Required area} &= \int_{-1}^1 (x_1 - x_2) dy = \int_{-1}^1 \left(\frac{y^2 + 3}{4} - \frac{y^2 + 1}{2} \right) dy = \int_{-1}^1 \left(\frac{-y^2 + 1}{4} \right) dy \\ &= \frac{1}{4} \left(\frac{-y^3}{3} + y \right)_{-1}^1 = \frac{1}{4} \left(\left(1 - \frac{1}{3} \right) - \left(\frac{1}{3} - 1 \right) \right) = \frac{1}{3} \end{aligned}$$

7 The coefficient of x^{101} in the expression $(5+x)^{500} + x(5+x)^{499} + x^2(5+x)^{498} + \dots + x^{500}$, $x > 0$, is

- (A) ${}^{501}C_{101} (5)^{399}$ (B) ${}^{501}C_{101} (5)^{400}$ (C) ${}^{501}C_{100} (5)^{400}$ (D) ${}^{500}C_{101} (5)^{399}$

NTA Ans. (A)

Reso Ans. (A)

Sol.

$$\begin{aligned} &(5+x)^{500} \left(1 - \left(\frac{x}{5+x} \right)^{501} \right) \\ &\quad \frac{1 - \frac{x}{5+x}}{5} \\ &(5+x)^{501} \frac{\left(1 - \frac{x^{501}}{(5+x)^{501}} \right)}{5} \\ &\quad \frac{1}{5} \left[(5+x)^{501} - x^{501} \right] \\ &\text{coefficient of } x^{101} \text{ is } \frac{1}{5} x^{501} C_{101} 5^{400} = {}^{501}C_{101} 5^{399} \end{aligned}$$

8 The sum $1 + 2 \cdot 3 + 3 \cdot 3^2 + \dots + 10 \cdot 3^9$ is equal to :

- A $\frac{2 \cdot 3^{12} + 10}{4}$
B $\frac{19 \cdot 3^{10} + 1}{4}$
C $5 \cdot 3^{10} - 2$
D $\frac{9 \cdot 3^{10} + 1}{2}$

NTA Ans. (B)

Reso Ans. (B)

Sol. $S_n = 1 + 2 \cdot 3^1 + 3 \cdot 3^2 + 4 \cdot 3^3 + \dots + 10 \cdot 3^9$
 $3S_n = 1 \cdot 3^1 + 2 \cdot 3^2 + 3 \cdot 3^3 + \dots + 10 \cdot 3^{10}$

Resonance Eduventures Ltd.

Reg. Office & Corp. Office : CG Tower, A-46 & 52, IPIA, Near City Mall, Jhalawar Road, Kota (Raj.) - 324005

Ph. No.: +91-744-2777777, 2777700 | FAX No. : +91-022-39167222

To Know more : sms RESO at 56677 | Website : www.resonance.ac.in | E-mail : contact@resonance.ac.in | CIN : U80302RJ2007PLC024029

Toll Free : 1800 258 5555 | 7340010333 | [facebook.com/ResonanceEdu](https://www.facebook.com/ResonanceEdu) | twitter.com/ResonanceEdu | www.youtube.com/resowatch | blog.resonance.ac.in

$$-2S_n = 1 + 3 + 3^2 + \dots + 3^9 - 10 \cdot 3^{10}$$

$$= \frac{1(3^{10} - 1)}{3 - 1} - 10 \cdot 3^{10}$$

$$= \frac{1}{2} \cdot 3^{10} - \frac{1}{2} - 3^{10} \cdot 10$$

$$-2S_n = -\frac{1}{2} - \frac{19}{2} \cdot 3^{10}$$

$$S_n = \frac{19}{4} 3^{10} + \frac{1}{4}$$

9 Let P be the plane passing through the intersection of the planes

$$\vec{r} \cdot (\hat{i} + 3\hat{j} - \hat{k}) = 5 \text{ and } \vec{r} \cdot (2\hat{i} - \hat{j} + \hat{k}) = 3, \text{ and the point } (2, 1, -2). \text{ Let the}$$

position vectors of the points X and Y be $\hat{i} - 2\hat{j} + 4\hat{k}$ and $5\hat{i} - \hat{j} + 2\hat{k}$ respectively. Then the points

- A X and $X + Y$ are on the same side of P
- B Y and $Y - X$ are on the opposite sides of P
- C X and Y are on the opposite sides of P
- D $X + Y$ and $X - Y$ are on the same side of P

NTA Ans. (C)

Reso Ans. (C)

10 A circle touches both the y -axis and the line $x + y = 0$. Then the locus of its center

- (A) $y = \sqrt{2}x$
- (B) $x = \sqrt{2}y$
- (C) $y^2 - x^2 = 2xy$
- (D) $x^2 - y^2 = 2xy$

NTA Ans. (D)

Reso Ans. (D)

Sol. Let centre of circle be $C(h, k)$

$$\therefore \text{circle touches } y\text{-axis} \Rightarrow \text{radius} = |h|$$

$$\therefore \text{circle touches } x - y = 0$$

$$\Rightarrow \frac{|h - k|}{\sqrt{2}} = |h|$$

$$\Rightarrow (h - k)^2 = 2h^2$$

$$\Rightarrow h^2 + k^2 - 2hk = 2h^2$$

$$\Rightarrow h^2 + 2hk - k^2 = 0$$

$$\text{locus of } (h, k) \rightarrow x^2 + 2xy - y^2 = 0$$

Resonance Eduventures Ltd.

Reg. Office & Corp. Office : CG Tower, A-46 & 52, IPIA, Near City Mall, Jhalawar Road, Kota (Raj.) - 324005

Ph. No.: +91-744-2777777, 2777700 | FAX No. : +91-022-39167222

To Know more : sms RESO at 56677 | Website : www.resonance.ac.in | E-mail : contact@resonance.ac.in | CIN : U80302RJ2007PLC024029

Toll Free : 1800 258 5555 | 7340010333 | [facebook.com/ResonanceEdu](https://www.facebook.com/ResonanceEdu) | twitter.com/ResonanceEdu | www.youtube.com/resowatch | blog.resonance.ac.in

11 Water is being filled at the rate of $1 \text{ cm}^3 / \text{sec}$ in a right circular conical vessel (vertex downwards) of height 35 cm and diameter 14 cm. When the height of the water level is 10 cm, the rate (in cm^2 / sec) at which the wet conical surface area of the vessel increases is

- (A) 5 (B) $\frac{\sqrt{21}}{5}$ (C) $\frac{\sqrt{26}}{5}$ (D) $\frac{\sqrt{26}}{10}$

NTA Ans. (C)

Reso Ans. (C)

12

If $b_n = \int_0^{\frac{\pi}{2}} \frac{\cos^2 nx}{\sin x} dx, n \in \mathbb{N}$, then

Question:

A $b_3 - b_2, b_4 - b_3, b_5 - b_4$ are in an A.P. with common difference -2

B $\frac{1}{b_3 - b_2}, \frac{1}{b_4 - b_3}, \frac{1}{b_5 - b_4}$ are in an A.P. with common difference 2

C $b_3 - b_2, b_4 - b_3, b_5 - b_4$ are in a G.P.

D $\frac{1}{b_3 - b_2}, \frac{1}{b_4 - b_3}, \frac{1}{b_5 - b_4}$ are in an A.P. with common difference -2

NTA Ans. (D)

Reso Ans. (D)

Sol.

$$b_n - b_{n-1} = \int_0^{\frac{\pi}{2}} \frac{\cos^2 nx - \cos^2 (n-1)x}{\sin x} dx = \int_0^{\frac{\pi}{2}} \frac{\sin(2n-1)x \sin(-x)}{\sin x} dx$$

$$= - \int_0^{\frac{\pi}{2}} \sin(2n-1)x dx = \frac{1}{2n-1} [\cos(2n-1)x]_0^{\frac{\pi}{2}} = - \frac{1}{2n-1}$$

$$b_n - b_{n-1} = - \frac{1}{2n-1}$$

$$\frac{1}{b_n - b_{n-1}} = -(2n-1)$$

$$\frac{1}{b_3 - b_2} = -5, \quad \frac{1}{b_4 - b_3} = -7, \quad \frac{1}{b_5 - b_4} = -9$$



common difference = -2

Resonance Eduventures Ltd.

Reg. Office & Corp. Office : CG Tower, A-46 & 52, IPIA, Near City Mall, Jhalawar Road, Kota (Raj.) - 324005

Ph. No.: +91-744-2777777, 2777700 | FAX No. : +91-022-39167222

To Know more : sms RESO at 56677 | Website : www.resonance.ac.in | E-mail : contact@resonance.ac.in | CIN : U80302RJ2007PLC024029

Toll Free : 1800 258 5555 |  7340010333 |  facebook.com/ResonanceEdu |  twitter.com/ResonanceEdu |  www.youtube.com/resovatch |  blog.resonance.ac.in

13 If $y = y(x)$ is the solution of the differential equation $2x^2 \frac{dy}{dx} - 2xy + 3y^2 = 0$ such that $y(e) = \frac{e}{3}$, then $y(1)$ is equal to

- (A) $\frac{1}{3}$ (B) $\frac{2}{3}$ (C) $\frac{3}{2}$ (D) 3

NTA Ans. (B)

Reso Ans. (B)

Sol.

$$2x^2 \frac{dy}{dx} - 2xy + 3y^2 = 0$$

$$\frac{1}{y^2} \frac{dy}{dx} - \frac{1}{xy} + \frac{3}{2x^2} = 0$$

$$\text{Let } \frac{1}{y} = t$$

$$\text{Difference of } -\frac{1}{y^2} \frac{dy}{dx} = \frac{dt}{dx}$$

$$-\frac{dt}{dx} - \frac{1}{x}t + \frac{3}{2x^2} = 0$$

$$\frac{dt}{dx} + \frac{1}{x}t = \frac{3}{2x^2}$$

$$\text{I.F.} = e^{\int \frac{1}{x} dx} = x$$

$$x.t. = \int x \cdot \frac{3}{2x^2} dx$$

$$x.t. = \frac{3}{2} \ln x + c$$

$$\frac{x}{y} = \frac{3}{2} \ln x + c$$

$$x = e, y = e/3$$

$$\frac{e}{e/3} = \frac{3}{2} \ln e + c$$

$$\Rightarrow c = \frac{3}{2}$$

$$\frac{x}{y} = \frac{3}{2} \ln x + \frac{3}{2}$$

$$\Rightarrow x = 1$$

$$\Rightarrow \frac{1}{y} = \frac{3}{2}$$

$$y = 2/3$$

Resonance Eduventures Ltd.

Reg. Office & Corp. Office : CG Tower, A-46 & 52, IPIA, Near City Mall, Jhalawar Road, Kota (Raj.) - 324005

Ph. No.: +91-744-2777777, 2777700 | FAX No. : +91-022-39167222

To Know more : sms RESO at 56677 | Website : www.resonance.ac.in | E-mail : contact@resonance.ac.in | CIN : U80302RJ2007PLC024029

Toll Free : 1800 258 5555 | 7340010333 | [facebook.com/ResonanceEdu](https://www.facebook.com/ResonanceEdu) | twitter.com/ResonanceEdu | www.youtube.com/resovatch | blog.resonance.ac.in

14 If the angle made by the tangent at the point (x_0, y_0) on the curve
 $x = 12(t + \sin t \cos t)$,
 $y = 12(1 + \sin t)^2$, $0 < t < \frac{\pi}{2}$, with the positive x-axis is $\frac{\pi}{3}$, then y_0 is equal to:

A $6(3 + 2\sqrt{2})$

B $3(7 + 4\sqrt{3})$

C 27

D 48

NTA Ans. (C)

Reso Ans. (C)

15 Question: The value of $2\sin(12^\circ) - \sin(72^\circ)$ is :

A $\frac{\sqrt{5}(1-\sqrt{3})}{4}$

B $\frac{1-\sqrt{5}}{8}$

C $\frac{\sqrt{3}(1-\sqrt{5})}{2}$

D $\frac{\sqrt{3}(1-\sqrt{5})}{4}$

NTA Ans. (D)

Reso Ans. (D)

Sol. $2(\sin(72^\circ - 60^\circ)) - \sin 72^\circ$
 $2\left(\sin 72^\circ \cdot \frac{1}{2} - \cos 72^\circ \cdot \frac{\sqrt{3}}{2}\right) - \sin 72^\circ$
 $-\sqrt{3} \cos(72^\circ)$
 $-\sqrt{3} \sin(18^\circ) = -\sqrt{3} \left(\frac{\sqrt{5}-1}{4}\right) = \sqrt{3} \left(\frac{1-\sqrt{5}}{4}\right)$

Resonance Eduventures Ltd.

Reg. Office & Corp. Office : CG Tower, A-46 & 52, IPIA, Near City Mall, Jhalawar Road, Kota (Raj.) - 324005

Ph. No.: +91-744-2777777, 2777700 | FAX No. : +91-022-39167222

To Know more : sms RESO at 56677 | Website : www.resonance.ac.in | E-mail : contact@resonance.ac.in | CIN : U80302RJ2007PLC024029

Toll Free : 1800 258 5555 | 7340010333 | [facebook.com/ResonanceEdu](https://www.facebook.com/ResonanceEdu) | twitter.com/ResonanceEdu | www.youtube.com/resowatch | blog.resonance.ac.in

16 A biased die is marked with numbers 2, 4, 8, 16, 32, 32 on its faces and the probability of getting a face with mark n is $\frac{1}{n}$. If the die is thrown thrice, then the probability, that the sum of the numbers obtained is 48, is :

- (A) $\frac{7}{2^{11}}$ (B) $\frac{7}{2^{12}}$ (C) $\frac{3}{2^{10}}$ (D) $\frac{13}{2^{12}}$

NTA Ans. (D)

Reso Ans. (D)

Sol.

Given $P(n) = \frac{1}{n}$

Favourable cases (16, 16, 16), (32, 8, 8), (8, 32, 8), (8, 8, 32)

$$\text{Prob} = \left(\frac{1}{16} \times \frac{1}{16} \times \frac{1}{16}\right) + 3 \times \left(\frac{1}{8} \times \frac{1}{8} \times \frac{1}{32}\right) = \frac{1}{2^{12}} + \frac{3}{2^{11}} = \frac{7}{2^{12}}$$

17 The negation of the Boolean expression $((\sim q) \wedge p) \Rightarrow ((\sim p) \vee q)$ is logically equivalent to :

- (A) $p \Rightarrow q$ (B) $q \Rightarrow p$ (C) $\sim (p \Rightarrow q)$ (D) $\sim (q \Rightarrow p)$

NTA Ans. (C)

Reso Ans. (C)

Sol.

$$\begin{aligned} (p \wedge \sim q) \wedge (p \vee \sim q) \\ = (p \wedge \sim q) \\ = \sim (p \rightarrow q) \end{aligned}$$

18 If the line $y = 4 + kx$, $k > 0$, is the tangent to the parabola $y = x - x^2$ at the point P and V is the vertex of the parabola, then the slope of the line through P and V is:

- (A) $\frac{3}{2}$ (B) $\frac{26}{9}$ (C) $\frac{5}{2}$ (D) $\frac{23}{6}$

NTA Ans. (C)

Reso Ans. (C)

Sol.

$$\begin{aligned} y &= kx + 4 \\ y &= x - x^2 \\ kx + 4 &= x - x^2 \quad \dots\dots\dots(1) \\ x^2 + (k-1)x + 4 &= 0 \\ (k-1)^2 - 4 \cdot 4 &= 0 \\ k-1 &= \pm 4 \\ \text{if } k &= 5 \\ \text{now put the value of } k &= 5 \\ 5x + 4 &= x - x^2 \\ x^2 + 4x + 4 &= 0 \\ (x+2)^2 &= 0 \\ x &= -2 \\ y &= -6 \\ \text{if } k &= -3 \end{aligned}$$

Resonance Eduventures Ltd.

Reg. Office & Corp. Office : CG Tower, A-46 & 52, IPIA, Near City Mall, Jhalawar Road, Kota (Raj.) - 324005

Ph. No.: +91-744-2777777, 2777700 | FAX No. : +91-022-39167222

To Know more : sms RESO at 56677 | Website : www.resonance.ac.in | E-mail : contact@resonance.ac.in | CIN : U80302RJ2007PLC024029

Toll Free : 1800 258 5555 |  7340010333 |  facebook.com/ResonanceEdu |  twitter.com/ResonanceEdu |  www.youtube.com/resowatch |  blog.resonance.ac.in

now put the value of $k = -3$ in equation (1)

$$-3x + 4 = x - x^2$$

$$x^2 - 4x + 4 = 0$$

$$x = 2 \quad y = -2$$

then the point of P is (2,-2) and (-2,-6)

and vertex of parabola 'O' = $y - \frac{1}{4} = -\frac{1}{4} + x - x^2$

$$y - \frac{1}{4} = -\left(x - \frac{1}{2}\right)^2$$

point P is (2,-2)

$$\text{slope of OP} = \frac{-2 - \frac{1}{4}}{2 - \frac{1}{2}} = -\frac{\frac{9}{4}}{\frac{3}{2}} = -\frac{3}{2}$$

point P is (-2,-6) slope of OP = $\frac{-6 - \frac{1}{4}}{-2 - \frac{1}{2}} = \frac{5}{2}$

19

The value of $\tan^{-1} \left(\frac{\cos\left(\frac{15\pi}{4}\right) - 1}{\sin\left(\frac{\pi}{4}\right)} \right)$ is equal to :

Question:

A $-\frac{\pi}{4}$

B $-\frac{\pi}{8}$

C $-\frac{5\pi}{12}$

D $-\frac{4\pi}{9}$

NTA Ans. (B)

Reso Ans. (B)

Sol.

$$\tan^{-1} \left(\frac{\frac{1}{\sqrt{2}} - 1}{\frac{1}{\sqrt{2}}} \right) = \tan^{-1} (1 - \sqrt{2}) = -\tan^{-1} (\sqrt{2} - 1) = -\frac{\pi}{8}$$

20

The line $y = x + 1$ meets the ellipse $\frac{x^2}{4} + \frac{y^2}{2} = 1$ at two points P and Q. If r is the

radius of the circle with PQ as diameter then $(3r)^2$ is equal to :

Resonance Eduventures Ltd.

Reg. Office & Corp. Office : CG Tower, A-46 & 52, IPIA, Near City Mall, Jhalawar Road, Kota (Raj.) - 324005

Ph. No.: +91-744-2777777, 2777700 | FAX No. : +91-022-39167222

To Know more : sms RESO at 56677 | Website : www.resonance.ac.in | E-mail : contact@resonance.ac.in | CIN : U80302RJ2007PLC024029

Toll Free : 1800 258 5555 | 7340010333 | [facebook.com/ResonanceEdu](https://www.facebook.com/ResonanceEdu) | twitter.com/ResonanceEdu | www.youtube.com/resowatch | blog.resonance.ac.in

(A) 20

(B) 12

(C) 11

(D) 8

NTA Ans. (A)

Reso Ans. (A)

Sol.

$$\frac{x^2}{4} + \frac{(x+1)^2}{2} = 1$$

$$x^2 + 2(x+1)^2 = 4$$

$$3x^2 + 4x - 2 = 0$$

$$(x_1 - x_2) = \sqrt{(x_1 + x_2)^2 - 4x_1x_2}$$

$$= \sqrt{\frac{16}{9} + \frac{8}{3}}$$

$$= \sqrt{\frac{40}{9}}$$

$$\text{also } (y_1 - y_2) = |x_1 - x_2| = \sqrt{\frac{40}{9}}$$

$$\text{radius} = \frac{1}{2} \sqrt{(x_1 - x_2)^2 + (y_1 - y_2)^2}$$

$$= \frac{1}{2} \sqrt{2 \times \frac{40}{9}}$$

$$= \frac{1}{2} \frac{\sqrt{80}}{3}$$

$$r = \frac{\sqrt{80}}{6}$$

$$(3r)^2 = 9r^2 = 9 \times \frac{80}{36} = 20$$

21

Let $A = \begin{pmatrix} 2 & -2 \\ 1 & -1 \end{pmatrix}$ and $B = \begin{pmatrix} -1 & 2 \\ -1 & 2 \end{pmatrix}$. Then the number of elements in the set $\{(n, m) : n, m \in \{1, 2, \dots, 10\} \text{ and } nA^n + mB^m = I\}$ is _____.

NTA Ans. 1

Reso Ans. 1

22

Let $f(x) = [2x^2 + 1]$ and $g(x) = \begin{cases} 2x - 3, & x < 0 \\ 2x + 3, & x \geq 0 \end{cases}$, where $[t]$ is the greatest

integer $\leq t$. Then, in the open interval $(-1, 1)$, the number of points where $f \circ g$ is discontinuous is equal to _____.

NTA Ans. 62





Reso Ans. 62

Resonance Eduventures Ltd.

Reg. Office & Corp. Office : CG Tower, A-46 & 52, IPIA, Near City Mall, Jhalawar Road, Kota (Raj.) - 324005

Ph. No.: +91-744-2777777, 2777700 | FAX No. : +91-022-39167222

To Know more : sms RESO at 56677 | Website : www.resonance.ac.in | E-mail : contact@resonance.ac.in | CIN : U80302RJ2007PLC024029

Toll Free : 1800 258 5555  7340010333  facebook.com/ResonanceEdu  twitter.com/ResonanceEdu  www.youtube.com/resowatch  blog.resonance.ac.in

23 The value of $b > 3$ for which $12 \int_3^b \frac{1}{(x^2-1)(x^2-4)} dx = \log_e \left(\frac{49}{40} \right)$, is equal to _____.

NTA Ans. 6

Reso Ans. 6

24 If the sum of the co-efficients of all the positive even powers of x in the binomial expansion of $\left(2x^3 + \frac{3}{x} \right)^{10}$ is $5^{10} - \beta \cdot 3^9$, then β is equal to _____.

NTA Ans. 83

Reso Ans. 83

25 If the mean deviation about the mean of the numbers $1, 2, 3, \dots, n$, where n is odd, is $\frac{5(n+1)}{n}$, then n is equal to _____.

NTA Ans. 21

Reso Ans. 21

Sol.
$$\bar{x} = \frac{1+2+3+\dots+n}{n} = \frac{\frac{n(n+1)}{2}}{n} = \frac{n+1}{2}$$
 (which is middle term)

$$\text{M.D.} = \frac{\sum |x_i - \bar{x}|}{n} = \frac{5(n+1)}{n}$$

$$\Rightarrow \frac{2 \left(1+2+3+\dots+\frac{(n-1)}{2} \right)}{n} = \frac{5(n+1)}{n}$$

$$\Rightarrow \frac{2 \cdot \left(\frac{(n-1)}{2} \left(\frac{(n-1)}{2} + 1 \right) \right)}{n} = \frac{5(n+1)}{n}$$

$$\Rightarrow \frac{(n-1)(n+1)}{4n} = \frac{5(n+1)}{n}$$

$$n = 21$$

26 Let $\vec{b} = \hat{i} + \hat{j} + \lambda \hat{k}$, $\lambda \in \mathbb{R}$. If \vec{a} is a vector such that $\vec{a} \times \vec{b} = 13\hat{i} - \hat{j} - 4\hat{k}$ and $\vec{a} \cdot \vec{b} + 21 = 0$, then $(\vec{b} - \vec{a}) \cdot (\hat{k} - \hat{j}) + (\vec{b} + \vec{a}) \cdot (\hat{i} - \hat{k})$ is equal to

NTA Ans. 14

Resonance Eduventures Ltd.

Reg. Office & Corp. Office : CG Tower, A-46 & 52, IPIA, Near City Mall, Jhalawar Road, Kota (Raj.) - 324005

Ph. No.: +91-744-2777777, 2777700 | FAX No. : +91-022-39167222

To Know more : sms RESO at 56677 | Website : www.resonance.ac.in | E-mail : contact@resonance.ac.in | CIN : U80302RJ2007PLC024029

Toll Free : 1800 258 5555 |  7340010333 |  facebook.com/ResonanceEdu |  twitter.com/ResonanceEdu |  www.youtube.com/resowatch |  blog.resonance.ac.in

Reso Ans. 14

27 The total number of three-digit numbers, with one digit repeated exactly two times, is _____.

NTA Ans. 243

Reso Ans. 243

28 Let $f(x) = |(x - 1)(x^2 - 2x - 3)| + x - 3$, $x \in \mathbb{R}$. If m and M are respectively the number of points of local minimum and local maximum of f in the interval $(0, 4)$, then $m + M$ is equal to _____.

NTA Ans. 3

Reso Ans. 3

Sol.

29 Let the eccentricity of the hyperbola $\frac{x^2}{a^2} - \frac{y^2}{b^2} = 1$ be $\frac{5}{4}$. If the equation of the normal at the point $\left(\frac{8}{\sqrt{5}}, \frac{12}{5}\right)$ on the hyperbola is $8\sqrt{5}x + \beta y = \lambda$, then $\lambda - \beta$ is equal to _____.

NTA Ans. 85

Reso Ans. 85

30 Let l_1 be the line in xy -plane with x and y intercepts $\frac{1}{8}$ and $\frac{1}{4\sqrt{2}}$ respectively, and l_2 be the line in xz -plane with x and z intercepts $-\frac{1}{8}$ and $-\frac{1}{6\sqrt{3}}$ respectively. If d is the shortest distance between the line l_1 and l_2 , then d^{-2} is equal to _____.

NTA Ans. 51

Reso Ans. 51

Resonance Eduventures Ltd.

Reg. Office & Corp. Office : CG Tower, A-46 & 52, IPIA, Near City Mall, Jhalawar Road, Kota (Raj.) - 324005

Ph. No.: +91-744-2777777, 2777700 | FAX No. : +91-022-39167222

To Know more : sms RESO at 56677 | Website : www.resonance.ac.in | E-mail : contact@resonance.ac.in | CIN : U80302RJ2007PLC024029

Toll Free : 1800 258 5555 | 7340010333 | [facebook.com/ResonanceEdu](https://www.facebook.com/ResonanceEdu) | twitter.com/ResonanceEdu | www.youtube.com/resowatch | blog.resonance.ac.in

Numbers that Inspire Students to **EXCEL**

Trust of
9,50,000+
STUDENTS*

Total Selections
1,78,546
JEE (Main) + Eligibility for
JEE (Adv.) + NEET UG

AIRs in **TOP-100**
350
JEE (Main) + JEE (Adv.)
+ NEET UG

Pool of
800+
FACULTY

Study Centres in
70+
CITIES

*Since 2001 | **Students Qualified from JEE (Main) to JEE (Advanced) since 2012 | Total Selections in AIR in TOP-100 mentioned are in JEE (Adv.) / JEE (Main) / AIEEE (since 2005), NEET (UG) / APMT (since 2012) | AIR: All India Rank

The 10-Building Blocks of **Proven & Trusted Teaching Methodology** @ Resonance

**Success is Assured
when you Do***

200 X Practice | 20 X Testing

1500+ Hrs. Classroom Teaching	10000+ Pages Study Material
45000+ Questions Practice Problems	50+ Tests 200+ Hrs. Testing & Assessment

* As per Latest Pattern of JEE (Main) & JEE (Advanced)

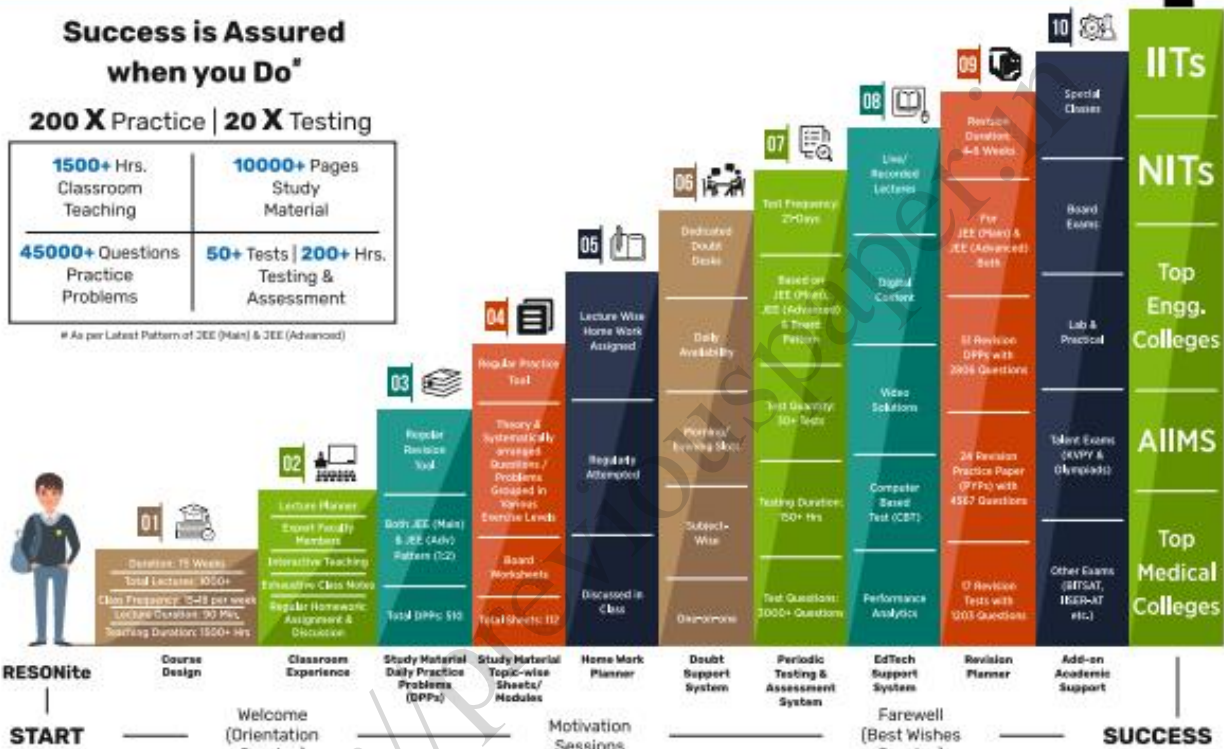

The figures (approx.) shown in the graph are of 2 Years Classroom Program (VIKAAS-XI & VIETA-XII) for JEE (Advanced) @ Resonance in Academic Session 2021-22. The figures vary for JEE (Main), NEET (UG) and Other Courses.

The Strong Faculty Team at Resonance Kota to deliver this successful Teaching Methodology



SCHOLARSHIP UPTO

100%

Based on JEE (Main) 2022 NTA Score (Percentile) & Scholarship Test (ResoNET)

Admission Announcement: 2022-23 | Class: 5 to 12 & 12+

ResoNET 3rd & 10th July
Resonance National Entrance Test

Target: JEE (Advanced) | JEE (Main) | NEET (UG) | Pre-Foundation (V to X) | Board

Polish your subject knowledge to Shine in JEE (Advanced) 2022 with the guidance of HODs & Top Notch Sr. Faculty of Resonance

SPARK 7 WEEKS COMPACT COURSE OFFLINE / ONLINE

from 4th July 2022

Scholarship upto 90%

Resonance Eduventures Ltd.

Follow us at

Kota Study Centre & Registered Corporate Office:
CG Tower, A-46 & 52, IPHA, Near City Mall,
Jhalawar Road, Kota (Raj.) - 324005

Tel No.: 0744-2777777, 2777700
Toll Free: 1800 258 5555 | CIN: U80302RJ2007PLC024029
e-mail: contact@resonance.ac.in | visit: www.resonance.ac.in



Resonance[®]
Educating for better tomorrow

JEE

(Main)

PAPER-1 (B.E./B. TECH.)

2022

COMPUTER BASED TEST (CBT) Questions & Solutions

Date: 25 June, 2022 (SHIFT-2) | TIME : (3.00 p.m. to 6.00 p.m)

Duration: 3 Hours | Max. Marks: 300

SUBJECT: CHEMISTRY

Resonance Eduventures Ltd.

Reg. Office & Corp. Office : CG Tower, A-46 & 52, IPIA, Near City Mall, Jhalawar Road, Kota (Raj.) - 324005

Ph. No.: +91-744-2777777, 2777700 | FAX No. : +91-022-39167222

To Know more : sms RESO at 56677 | Website : www.resonance.ac.in | E-mail : contact@resonance.ac.in | CIN : U80302RJ2007PLC024029

Toll Free : 1800 258 5555  7340010333  facebook.com/ResonanceEdu  twitter.com/ResonanceEdu  www.youtube.com/resowatch  blog.resonance.ac.in

This solution was download from Resonance JEE (MAIN) 2022 Solution portal

PART : CHEMISTRY

1 The minimum energy that must be possessed by photons in order to produce the photoelectric effect with platinum metal is:

[Given: The threshold frequency of platinum is $1.3 \times 10^{15} \text{ s}^{-1}$ and $h = 6.6 \times 10^{-34} \text{ J s.}$]

A $3.21 \times 10^{-14} \text{ J}$

B $6.24 \times 10^{-16} \text{ J}$

C $8.58 \times 10^{-19} \text{ J}$

D $9.76 \times 10^{-20} \text{ J}$

Ans (C)

Sol. $E = E_0 + KE$

For minimum energy $E = E_0$

$$E = \left(\frac{hc}{\lambda}\right) = hv$$

$$= 6.6 \times 10^{-34} \times 1.3 \times 10^{15}$$

$$= 8.58 \times 10^{-19} \text{ J}$$

2 At 25°C and 1 atm pressure, the enthalpy of combustion of benzene (l) and acetylene (g) are $-3268 \text{ kJ mol}^{-1}$ and $-1300 \text{ kJ mol}^{-1}$, respectively. The change in enthalpy for the reaction $3 \text{ C}_2\text{H}_2(\text{g}) \leftrightarrow \text{C}_6\text{H}_6(\text{l})$, is

A $+324 \text{ kJ mol}^{-1}$

B $+632 \text{ kJ mol}^{-1}$

C -632 kJ mol^{-1}

D -732 kJ mol^{-1}

Ans (C)

Sol. $\Delta H_r = (\Delta H_c)_{\text{reactant}} - (\Delta H_c)_{\text{product}}$

$$= 3[\Delta H_c(\text{C}_2\text{H}_2, \text{g})] - [\Delta H_c(\text{C}_6\text{H}_6, \text{l})]$$

$$= 3 \times (-1300) - (-3268)$$





$$= -3900 + 3268 = -632 \text{ kJ/mole}$$

Resonance Eduventures Ltd.

Reg. Office & Corp. Office : CG Tower, A-46 & 52, IPIA, Near City Mall, Jhalawar Road, Kota (Raj.) - 324005

Ph. No.: +91-744-2777777, 2777700 | FAX No. : +91-022-39167222

To Know more : sms RESO at 56677 | Website : www.resonance.ac.in | E-mail : contact@resonance.ac.in | CIN : U80302RJ2007PLC024029

Toll Free : 1800 258 5555  7340010333  facebook.com/ResonanceEdu  twitter.com/ResonanceEdu  www.youtube.com/resowatch  blog.resonance.ac.in

3 Solute A associates in water. When 0.7 g of solute A is dissolved in 42.0 g of water, it depresses the freezing point by 0.2 °C. The percentage association of solute A in water, is :

[Given: Molar mass of A = 93 g mol⁻¹. Molal depression constant of water is 1.86 K kg mol⁻¹.]

- A 50%
- B 60%
- C 70%
- D 80%

Ans (D)

Sol. $\Delta T_f = i[K_f \times m]$

$$2.0 = i \left[1.86 \times \frac{7 \times 1000}{93 \times 42} \right]$$

$$2.0 = i[3.33]$$

$$i = 0.6$$

$$i = 1 + \left[\frac{1}{n} - 1 \right] \beta$$

$$0.6 = 1 + \left[\frac{1}{2} - 1 \right] \beta$$

$$\beta = 0.8$$

$$\% \beta = 80$$

4 The K_{sp} for bismuth sulphide (Bi_2S_3) is 1.08×10^{-73} . The solubility of Bi_2S_3 in mol L⁻¹ at 298 K is

- A 1.0×10^{-15}
- B 2.7×10^{-12}
- C 3.2×10^{-10}
- D 4.2×10^{-8}

Ans (A)

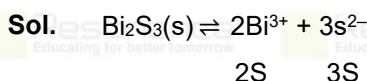

$$K_{sp}(\text{Bi}_2\text{S}_3) = (2S)^2 (3S)^3$$

$$= (2)^2(3)^3 (S)^5$$

$$1.08 \times 10^{-73} = 4 \times 27(S)^5$$

Resonance Eduventures Ltd.

Reg. Office & Corp. Office : CG Tower, A-46 & 52, IPIA, Near City Mall, Jhalawar Road, Kota (Raj.) - 324005

Ph. No.: +91-744-2777777, 2777700 | FAX No. : +91-022-39167222

To Know more : sms RESO at 56677 | Website : www.resonance.ac.in | E-mail : contact@resonance.ac.in | CIN : U80302RJ2007PLC024029

Toll Free : 1800 258 5555  7340010333  facebook.com/ResonanceEdu  twitter.com/ResonanceEdu  www.youtube.com/resowatch  blog.resonance.ac.in

$$108 \times 10^{-75} = 108(S)^5$$

$$S = 1 \times 10^{-15}$$

5 Match List I with List II.

List I	List II
A. Zymase	I. Stomach
B. Diastase	II. Yeast
C. Urease	III. Malt
D. Pepsin	IV. Soyabean

Choose the correct answer from the options given below:

- A A-II, B-III, C-I, D-IV
- B A-II, B-III, C-IV, D-I
- C A-III, B-II, C-IV, D-I
- D A-III, B-II, C-I, D-IV

Ans (B)

6 The correct order of electron gain enthalpies of Cl, F, Te and Po is

- A 1.0×10^{-15}
- B 2.7×10^{-12}
- C 3.2×10^{-10}
- D 4.2×10^{-8}

Ans (B)

Sol. Element Electron Gain Enthalpies (kJ mol⁻¹)

F	-328
Cl	-349
Te	-190
Po	-174

Resonance Eduventures Ltd.

Reg. Office & Corp. Office : CG Tower, A-46 & 52, IPIA, Near City Mall, Jhalawar Road, Kota (Raj.) - 324005

Ph. No.: +91-744-2777777, 2777700 | FAX No. : +91-022-39167222

To Know more : sms RESO at 56677 | Website : www.resonance.ac.in | E-mail : contact@resonance.ac.in | CIN : U80302RJ2007PLC024029

Toll Free : 1800 258 5555  7340010333  facebook.com/ResonanceEdu  twitter.com/ResonanceEdu  www.youtube.com/resowatch  blog.resonance.ac.in

7 Given below are two statements.

Statement I: During electrolytic refining, blister copper deposits precious metals.

Statement II: In the process of obtaining pure copper by electrolysis method, copper blister is used to make the anode.

In the light of the above statements, choose the *correct* answer from the options given below.

- A Both Statement I and Statement II are true.
- B Both Statement I and Statement II are false.
- C Statement I is true but Statement II is false.
- D Statement I is false but Statement II is true.

Ans (A)

Sol. Impure Cu obtained from ores is converted to pure Cu in an electrolyte cell that the impure copper as the anode and pure copper as the cathode. The electrolyte is an aqueous solution of CuSO_4 . At the impure Cu anode, Cu is oxidized along with the more easily oxidized metallic impurities such as Zn and Fe. The less easily oxidized impurities such as Ag, Au, and Pt fall to the bottom of the cell as anode mud, which is reprocessed to recover the precious metals. At the pure Cu cathode, Cu^{2+} ions get reduced to pure copper metal

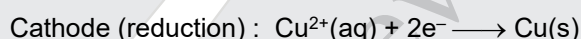

Thus, the net cell reaction simply involves transfer of Cu metal from the impure anode to the pure cathode, Cu obtained by this process is 99.95% pure.

8 Given below are two statements one is labelled as **Assertion A** and the other is labelled as **Reason R** :

Assertion A : The amphoteric nature of water is explained by using Lewis acid/base concept.

Reason R : Water acts as an acid with NH_3 and as a base with H_2S .





In the light of the above statements choose the *correct* answer from the options given below :

Resonance Eduventures Ltd.

Reg. Office & Corp. Office : CG Tower, A-46 & 52, IPIA, Near City Mall, Jhalawar Road, Kota (Raj.) - 324005

Ph. No.: +91-744-2777777, 2777700 | FAX No. : +91-022-39167222

To Know more : sms RESO at 56677 | Website : www.resonance.ac.in | E-mail : contact@resonance.ac.in | CIN : U80302RJ2007PLC024029

Toll Free : 1800 258 5555  7340010333  facebook.com/ResonanceEdu  twitter.com/ResonanceEdu  www.youtube.com/resowatch  blog.resonance.ac.in

- A Both A and R are true and R is the correct explanation of A.
 B Both A and R are true but R is NOT the correct explanation of A.
 C A is true but R is false.
 D A is false but R is true.

Ans (D)

Sol. According to Lewis concept water act as Base.

9 The correct order of reduction potentials of the following pairs is

- A. Cl_2/Cl^-
 B. I_2/I^-
 C. Ag^+/Ag
 D. Na^+/Na
 E. Li^+/Li

Choose the correct answer from the options given below.

- A $\text{A} > \text{C} > \text{B} > \text{D} > \text{E}$
 B $\text{A} > \text{B} > \text{C} > \text{D} > \text{E}$
 C $\text{A} > \text{C} > \text{B} > \text{E} > \text{D}$
 D $\text{A} > \text{B} > \text{C} > \text{E} > \text{D}$

Ans (A)

Sol. $E^\circ_{\text{Cl}_2/\text{Cl}^-} = 1.36\text{V}$

$E^\circ_{\text{I}_2/\text{I}^-} = +0.54\text{V}$

$E^\circ_{\text{Ag}^+/\text{Ag}} = 0.80\text{V}$

$E^\circ_{\text{Na}^+/\text{Na}} = -2.71\text{V}$

$E^\circ_{\text{Li}^+/\text{Li}} = -3.05\text{V}$

10 The number of bridged oxygen atoms present in compound B formed from the following reactions is

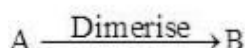

A 0

Resonance Eduventures Ltd.

Reg. Office & Corp. Office : CG Tower, A-46 & 52, IPIA, Near City Mall, Jhalawar Road, Kota (Raj.) - 324005

Ph. No.: +91-744-2777777, 2777700 | FAX No. : +91-022-39167222

To Know more : sms RESO at 56677 | Website : www.resonance.ac.in | E-mail : contact@resonance.ac.in | CIN : U80302RJ2007PLC024029

Toll Free : 1800 258 5555  7340010333  facebook.com/ResonanceEdu  twitter.com/ResonanceEdu  www.youtube.com/resowatch  blog.resonance.ac.in

- B** 1
C 2
D 3

Ans (A)

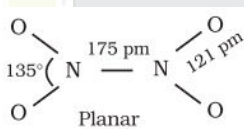
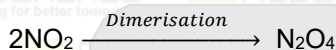
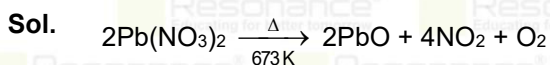

11 The metal ion (in gaseous state) with lowest spin-only magnetic moment value is

- A** V^{2+}
B Ni^{2+}
C Cr^{2+}
D Fe^{2+}

Ans (B)

Sol.

	Ion	Electronic configuration	No. of unpaired electron
(1)	Cr^{2+}	$3d^4$	4
(2)	V^{2+}	$3d^3$	3
(3)	Fe^{2+}	$3d^6$	4
(4)	Ni^{2+}	$3d^8$	2

Less is no. of unpaired electron less is magnetic moment (spin only).

12 Given below are two statements: one is labelled as **Assertion A** and the other is labelled as **Reason R**.

Assertion A: Polluted water may have a value of BOD of the order of 17 ppm.

Reason R: BOD is a measure of oxygen required to oxidise both the biodegradable and non-biodegradable organic material in water.

In the light of the above statements, choose the *most appropriate* answer from the options given below.

Resonance Eduventures Ltd.

Reg. Office & Corp. Office : CG Tower, A-46 & 52, IPIA, Near City Mall, Jhalawar Road, Kota (Raj.) - 324005

Ph. No.: +91-744-2777777, 2777700 | FAX No. : +91-022-39167222

To Know more : sms RESO at 56677 | Website : www.resonance.ac.in | E-mail : contact@resonance.ac.in | CIN : U80302RJ2007PLC024029

Toll Free : 1800 258 5555 7340010333 facebook.com/ResonanceEdu twitter.com/ResonanceEdu www.youtube.com/resowatch blog.resonance.ac.in

- A Both A and R are correct and R is the correct explanation of A.
- B Both A and R are correct but R is NOT the correct explanation of A.
- C A is correct but R is not correct.
- D A is not correct but R is correct.

Ans (C)

Sol. The amount of BOD in the water is a measure of the amount of organic material in the water, in terms of how much oxygen will be required to break it down biologically. Clean water would have BOD value of less than 5 ppm whereas highly polluted water could have a BOD value of 17 ppm or more.

13

Given below are two statements: one is labelled as **Assertion A** and the other is labelled as **Reason R**.

Assertion A: A mixture contains benzoic acid and naphthalene. The pure benzoic acid can be separated out by the use of benzene.

Reason R: Benzoic acid is soluble in hot water.

In the light of the above statements, choose the *most appropriate* answer from the options given below.

- A Both A and R are true and R is the correct explanation of A.
- B Both A and R are true but R is NOT the correct explanation of A.
- C A is true but R is false.
- D A is false but R is true.

Ans (D)

Sol. Aromatic acids are insoluble in water but soluble in aqueous NaHCO_3 solution or NaOH solution, due to salt formation.

14

During halogen test, sodium fusion extract is boiled with concentrated HNO_3 to

- A remove unreacted sodium
- B decompose cyanide or sulphide of sodium
- C extract halogen from organic compound
- D maintain the pH of extract.





Ans (B)

Resonance Eduventures Ltd.

Reg. Office & Corp. Office : CG Tower, A-46 & 52, IPIA, Near City Mall, Jhalawar Road, Kota (Raj.) - 324005

Ph. No.: +91-744-2777777, 2777700 | FAX No. : +91-022-39167222

To Know more : sms RESO at 56677 | Website : www.resonance.ac.in | E-mail : contact@resonance.ac.in | CIN : U80302RJ2007PLC024029

Toll Free : 1800 258 5555  7340010333  facebook.com/ResonanceEdu  twitter.com/ResonanceEdu  www.youtube.com/resowatch  blog.resonance.ac.in

Sol. The sodium fusion extract is first boiled with concentrated nitric acid to decompose cyanide or sulphide of sodium formed during Lassaigne's test. These ions would otherwise interfere with silver nitrate test for halogens.

15 Amongst the following, the major product of the given chemical reaction is

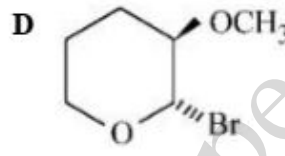
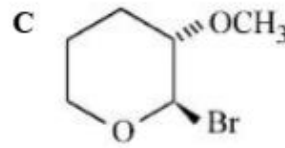
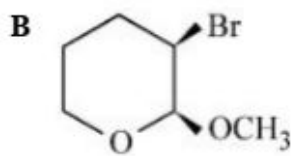
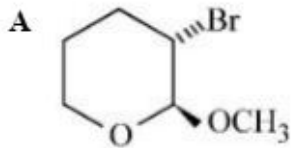
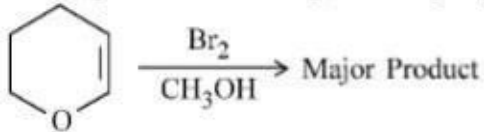

Ans (A)

Sol. The reaction proceed via cyclic bromonium ion with anti addition mechanism.

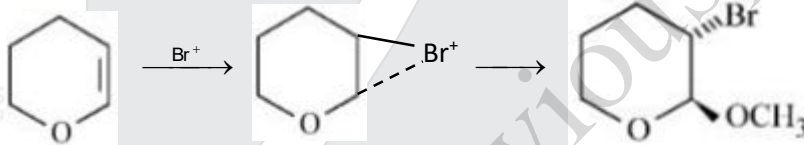

16 In the given reaction

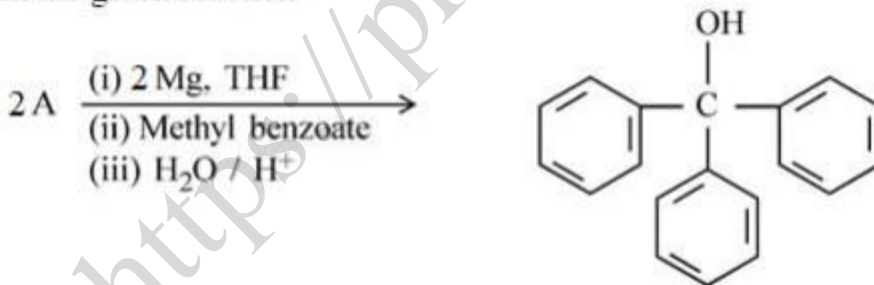

'A' can be

Resonance Eduventures Ltd.

Reg. Office & Corp. Office : CG Tower, A-46 & 52, IPIA, Near City Mall, Jhalawar Road, Kota (Raj.) - 324005

Ph. No.: +91-744-2777777, 2777700 | FAX No. : +91-022-39167222

To Know more : sms RESO at 56677 | Website : www.resonance.ac.in | E-mail : contact@resonance.ac.in | CIN : U80302RJ2007PLC024029

Toll Free : 1800 258 5555  7340010333  facebook.com/ResonanceEdu  twitter.com/ResonanceEdu  www.youtube.com/resowatch  blog.resonance.ac.in

- A benzyl bromide
- B bromobenzene
- C cyclohexyl bromide
- D methyl bromide

Ans (B)

Sol.

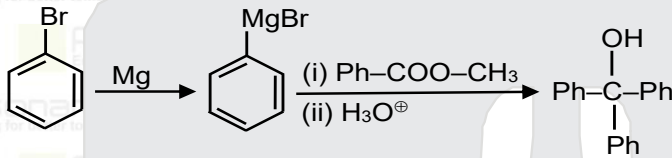

17 Which of the following conditions or reaction sequence will NOT give acetophenone as the major product ?

- A
(a) $\text{C}_6\text{H}_5\text{CHO} + \text{CH}_3\text{MgBr}$ (b) $\text{Na}_2\text{Cr}_2\text{O}_7, \text{H}^+$
- B
(a) $\text{H}_3\text{CCHO} + \text{C}_6\text{H}_5\text{MgBr}$ (b) PCC, DCM
- C
 $\text{C}_6\text{H}_5\text{COOC}_2\text{H}_5 + 2\text{CH}_3\text{MgBr}$
- D
 $\text{C}_6\text{H}_5\text{COCl} + \text{CH}_3\text{MgBr} + \text{CdCl}_2$

Ans (C)

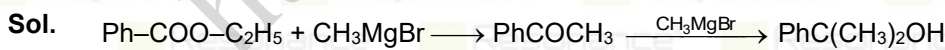

18 The major product formed in the following reaction, is

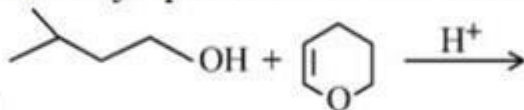

Resonance Eduventures Ltd.

Reg. Office & Corp. Office : CG Tower, A-46 & 52, IPIA, Near City Mall, Jhalawar Road, Kota (Raj.) - 324005

Ph. No.: +91-744-2777777, 2777700 | FAX No. : +91-022-39167222

To Know more : sms RESO at 56677 | Website : www.resonance.ac.in | E-mail : contact@resonance.ac.in | CIN : U80302RJ2007PLC024029

Toll Free : 1800 258 5555 | 7340010333 | [facebook.com/ResonanceEdu](https://www.facebook.com/ResonanceEdu) | twitter.com/ResonanceEdu | www.youtube.com/resowatch | blog.resonance.ac.in

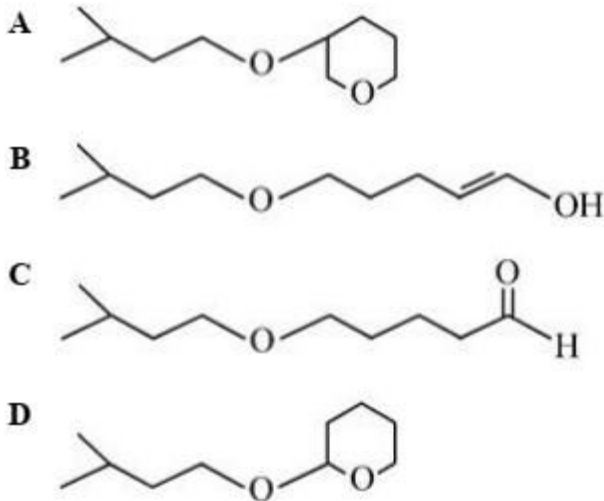

Ans (D)

Sol.

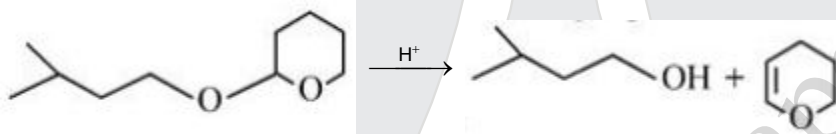

19 Which of the following ketone will NOT give enamine on treatment with secondary amines? [where t-Bu is $-\text{C}(\text{CH}_3)_3$]

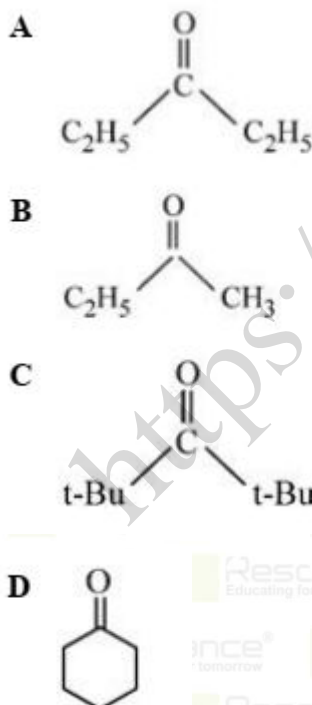

Ans (C)

Resonance Eduventures Ltd.

Reg. Office & Corp. Office : CG Tower, A-46 & 52, IPIA, Near City Mall, Jhalawar Road, Kota (Raj.) - 324005

Ph. No.: +91-744-2777777, 2777700 | FAX No. : +91-022-39167222

To Know more : sms RESO at 56677 | Website : www.resonance.ac.in | E-mail : contact@resonance.ac.in | CIN : U80302RJ2007PLC024029

Toll Free : 1800 258 5555  7340010333  facebook.com/ResonanceEdu  twitter.com/ResonanceEdu  www.youtube.com/resowatch  blog.resonance.ac.in

Sol.

$t\text{-Bu}-\overset{\text{O}}{\parallel}{\text{C}}-t\text{-Bu}$ neither has α H, as well as sterically crowded for any nucleophilic attack by 2° amine.

20 An antiseptic dettol is a mixture of two compounds 'A' and 'B' where A has 6π electrons and B has 2π electrons. What is 'B'?

- A Bithionol
- B Terpineol
- C Chloroxylenol
- D Chloramphenicol

Ans (B)

Sol.

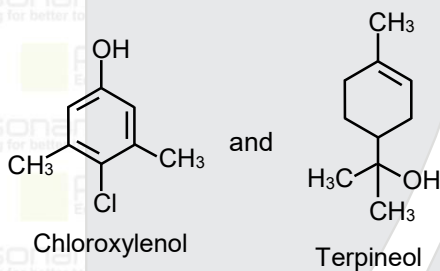

21 A protein 'A' contains 0.30% of glycine (molecular weight 75). The minimum molar mass of the protein 'A' is _____ $\times 10^3 \text{ g mol}^{-1}$ [nearest integer]

Ans (25)

Sol. % of glycine = $\left[\frac{75 \times 1}{\text{GMM}} \right] \times 100 = 0.3$

$\text{GMM} = \left[\frac{75 \times 100}{0.3} \right] = 25 \times 10^3$

22 A rigid nitrogen tank stored inside a laboratory has a pressure of 30 atm at 06:00 am when the temperature is 27°C . At 03:00 pm, when the temperature is 45°C , the pressure in the tank will be _____ atm. [nearest integer]

Ans (32)

Sol. At constant volume and mole

$\frac{P_1}{T_1} = \frac{P_2}{T_2}$

$\frac{30}{300} = \frac{P_2}{318}$

Resonance Eduventures Ltd.

Reg. Office & Corp. Office : CG Tower, A-46 & 52, IPIA, Near City Mall, Jhalawar Road, Kota (Raj.) - 324005

Ph. No.: +91-744-2777777, 2777700 | FAX No. : +91-022-39167222

To Know more : sms RESO at 56677 | Website : www.resonance.ac.in | E-mail : contact@resonance.ac.in | CIN : U80302RJ2007PLC024029

Toll Free : 1800 258 5555  7340010333  facebook.com/ResonanceEdu  twitter.com/ResonanceEdu  www.youtube.com/resowatch  blog.resonance.ac.in

$$P_2 = \left(\frac{30}{300}\right) \times 318 = 31.8 \approx 32$$

23 Amongst BeF_2 , BF_3 , H_2O , NH_3 , CCl_4 and HCl , the number of molecules with non-zero net dipole moment is _____.

Ans (3)

Sol. Polar molecules = H_2O , NH_3 , HCl

Non-polar molecules = BeF_2 , BF_3 , CCl_4

24 At 345 K, the half life for the decomposition of a sample of a gaseous compound initially at 55.5 kPa was 340 s. When the pressure was 27.8 kPa, the half life was found to be 170 s. The order of the reaction is _____. [integer answer]

Ans (0)

Sol.

$$\frac{(t_{1/2})_1}{(t_{1/2})_2} = \left(\frac{P_1}{P_2}\right)^{1-n} \Rightarrow \frac{340}{170} = \left(\frac{55.5}{27.8}\right)^{1-n}$$

$$(2)^1 = (2)^{1-n}$$

$$1 = 1 - n \Rightarrow n = 0$$

25 A solution of $\text{Fe}_2(\text{SO}_4)_3$ is electrolyzed for 'x' min with a current of 1.5 A to deposit 0.3482 g of Fe. The value of x is _____. [nearest integer]

Given : 1 F = 96500 C mol⁻¹

Atomic mass of Fe = 56 g mol⁻¹

Ans (20)

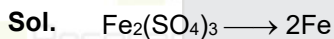

$$w = Zit$$

$$w = \left(\frac{E}{96500}\right) it$$

$$0.3482 = \left(\frac{56}{3 \times 96500}\right) \times 1.5 \times t$$





$$t = 1200 \text{ sec} = 20 \text{ min}$$

Resonance Eduventures Ltd.

Reg. Office & Corp. Office : CG Tower, A-46 & 52, IPIA, Near City Mall, Jhalawar Road, Kota (Raj.) - 324005

Ph. No.: +91-744-2777777, 2777700 | FAX No. : +91-022-39167222

To Know more : sms RESO at 56677 | Website : www.resonance.ac.in | E-mail : contact@resonance.ac.in | CIN : U80302RJ2007PLC024029

Toll Free : 1800 258 5555  7340010333  facebook.com/ResonanceEdu  twitter.com/ResonanceEdu  www.youtube.com/resowatch  blog.resonance.ac.in

26 Consider the following reactions :

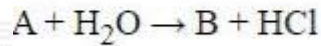
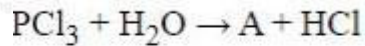

The number of ionisable protons present in the product B is _____.

Ans (2)

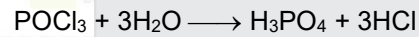
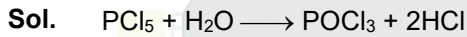

No. of ionisable hydrogen = 3

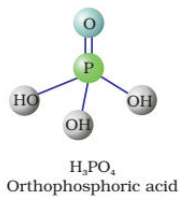

27 Amongst $\text{FeCl}_3 \cdot 3\text{H}_2\text{O}$, $\text{K}_3[\text{Fe}(\text{CN})_6]$ and $[\text{Co}(\text{NH}_3)_6]\text{Cl}_3$, the spin-only magnetic moment value of the inner-orbital complex that absorbs light at shortest wavelength is _____ B.M. [nearest integer]

Ans (2)

Sol.	Complex	EC	Hybridisation	No. of unpaired e ⁻
(i)	$\text{FeCl}_3 \cdot 3\text{H}_2\text{O}$	$\text{Fe}^{3+} = 3d^5$	sp^3d^2	5
(ii)	$\text{K}_3[\text{Fe}(\text{CN})_6]$	$\text{Fe}^{3+} = 3d^5$	d^2sp^3	1
(iii)	$[\text{Co}(\text{NH}_3)_6]^{3+}$	$\text{Co}^{3+} = 3d^6$	d^2sp^3	0

CN^- is strong ligand than NH_3 so splitting in $\text{K}_3[\text{Fe}(\text{CN})_6]$ is higher and it absorb light of shortest wave length]

$$\mu(\text{spin only}) = \sqrt{n(n+2)} = \sqrt{3} = 1.73 \text{ BM} \approx 2 \text{ BM}$$

28 The Novolac polymer has mass of 963 g. The number of monomer units present in it are

Ans (9)

Sol.

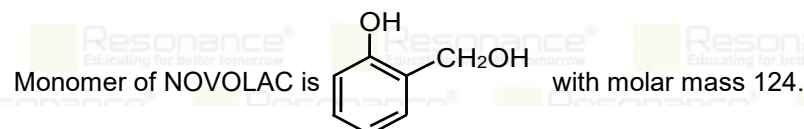





Resonance Eduventures Ltd.

Reg. Office & Corp. Office : CG Tower, A-46 & 52, IPIA, Near City Mall, Jhalawar Road, Kota (Raj.) - 324005

Ph. No.: +91-744-2777777, 2777700 | FAX No. : +91-022-39167222

To Know more : sms RESO at 56677 | Website : www.resonance.ac.in | E-mail : contact@resonance.ac.in | CIN : U80302RJ2007PLC024029

Toll Free : 1800 258 5555 | 7340010333 |  facebook.com/ResonanceEdu |  twitter.com/ResonanceEdu |  www.youtube.com/resowatch |  blog.resonance.ac.in

Let there is n no. of monomer unit, therefore in Novalac formation (n-1) unit of water is removed.

or $n \times 124 = 963 + (n-1) \times 18$

$n = 9.$

29 How many of the given compounds will give a positive Biuret test _____ ?
Glycine, Glycylalanine, Tripeptide, Biuret

Ans (2)

Sol. Tripeptide, only species with peptide bond gives biureate test.

30 The neutralization occurs when 10 mL of 0.1M acid 'A' is allowed to react with 30 mL of 0.05 M base M(OH)₂. The basicity of the acid 'A' is _____.

[M is a metal]

Ans (3)

Sol. Let basicity of acid is x

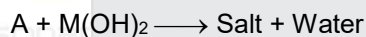

At complete neturization.

Milli eq. of acid = Milli eq. of base

$$n[0.1 \times 10] = 2[0.05 \times 30]$$





$$n = 3$$

Resonance Eduventures Ltd.

Reg. Office & Corp. Office : CG Tower, A-46 & 52, IPIA, Near City Mall, Jhalawar Road, Kota (Raj.) - 324005

Ph. No.: +91-744-2777777, 2777700 | FAX No. : +91-022-39167222

To Know more : sms RESO at 56677 | Website : www.resonance.ac.in | E-mail : contact@resonance.ac.in | CIN : U80302RJ2007PLC024029

Toll Free : 1800 258 5555  7340010333  facebook.com/ResonanceEdu  twitter.com/ResonanceEdu  www.youtube.com/resowatch  blog.resonance.ac.in

Numbers that Inspire Students to **EXCEL**

Trust of
9,50,000+
STUDENTS*

Total Selections
1,78,546
JEE (Main) + Eligibility for
JEE (Adv.) + NEET UG

AIRs in **TOP-100**
350
JEE (Main) + JEE (Main)
+ NEET UG

Pool of
800+
FACULTY

Study Centres in
70+
CITIES

*Since 2001 | **Students Qualified from JEE (Main) to JEE (Advanced) since 2012 | Total Selections in AIR in TOP-100 mentioned are in JEE (Adv.) / JEE (Main) since 2002, JEE (Main) / AIEEE (since 2005), NEET (UG) / APMT (since 2012) | AIR in India Rank

The 10-Building Blocks of **Proven & Trusted Teaching Methodology** @ Resonance

**Success is Assured
when you Do***

200 X Practice | 20 X Testing

1500+ Hrs. Classroom Teaching	10000+ Pages Study Material
45000+ Questions Practice Problems	50+ Tests 200+ Hrs. Testing & Assessment

* As per Latest Pattern of JEE (Main) & JEE (Advanced)

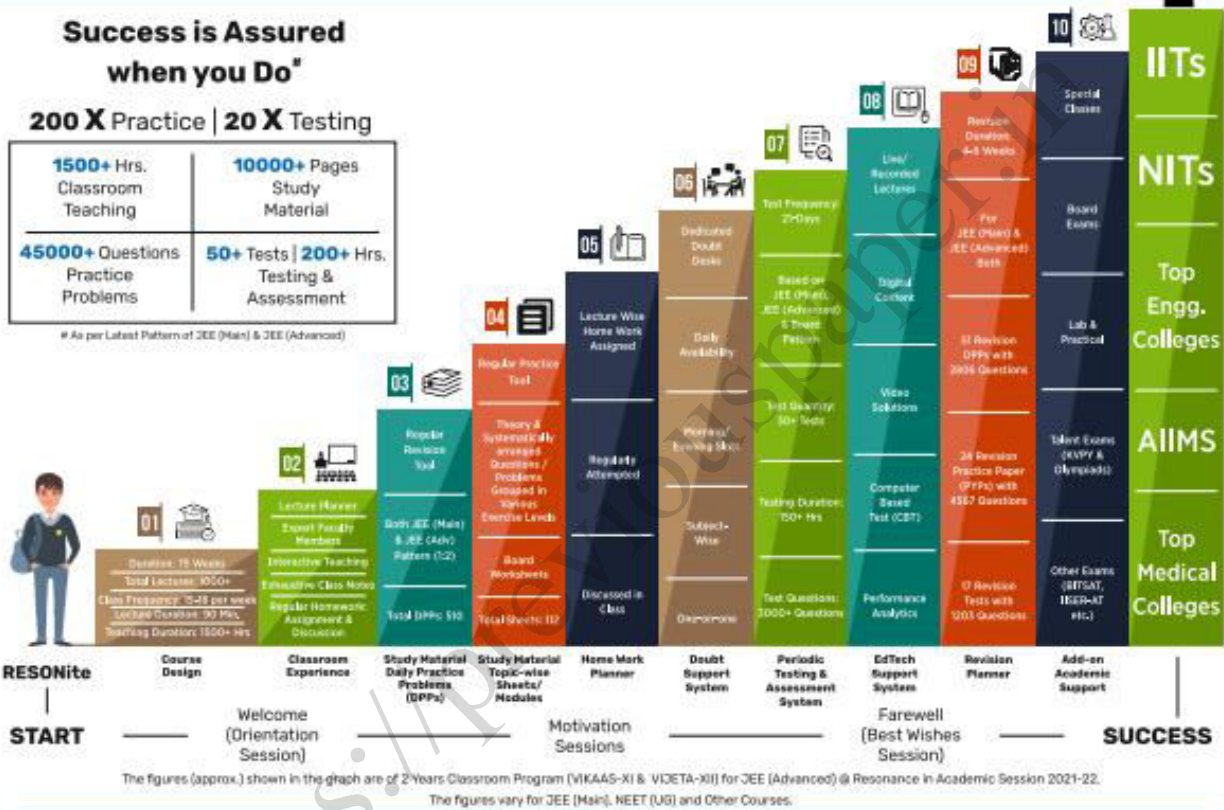

The Strong Faculty Team at Resonance Kota to deliver this successful Teaching Methodology



SCHOLARSHIP UPTO

100%

Based on JEE (Main) 2022 NTA Score (Percentile) & Scholarship Test (ResoNET)

Admission Announcement: 2022-23 | Class: 5 to 12 & 12+

ResoNET 3rd & 10th July

Target: JEE (Advanced) | JEE (Main) | NEET (UG) | Pre-Foundation (V to X) | Board

Polish your subject knowledge to Shine in JEE (Advanced) 2022 with the guidance of HODs & Top Notch Sr. Faculty of Resonance

SPARK 7 WEEKS COMPACT COURSE OFFLINE / ONLINE

from 4th July 2022

Scholarship upto 90%

Resonance Eduventures Ltd.

Follow us at

Kota Study Centre & Registered Corporate Office:
CG Tower, A-46 & 52, IPHA, Near City Mall,
Jhalawar Road, Kota (Ra.) - 324005

Tel No.: 0744-2777777, 2777700

Toll Free: 1800 258 5555 | CIN: U80302RJ2007PLC024029

e-mail: contact@resonance.ac.in | visit: www.resonance.ac.in



Resonance[®]
Educating for better tomorrow

JEE
(Main)

PAPER-1 (B.E./B. TECH.)

2022

COMPUTER BASED TEST (CBT)
Questions & Solutions

Date: 25 June, 2022 (SHIFT-2) | TIME : (3.00 p.m. to 6.00 p.m)

Duration: 3 Hours | Max. Marks: 300



SUBJECT: PHYSICS

Resonance Eduventures Ltd.

Reg. Office & Corp. Office : CG Tower, A-46 & 52, IPIA, Near City Mall, Jhalawar Road, Kota (Raj.) - 324005

Ph. No.: +91-744-2777777, 2777700 | FAX No. : +91-022-39167222

To Know more : sms RESO at 56677 | Website : www.resonance.ac.in | E-mail : contact@resonance.ac.in | CIN : U80302RJ2007PLC024029

Toll Free : 1800 258 5555  7340010333  facebook.com/ResonanceEdu  twitter.com/ResonanceEdu  www.youtube.com/resowatch  blog.resonance.ac.in

This solution was download from Resonance JEE (MAIN) 2022 Solution portal

PART : PHYSICS

- 1 Given below are two statements. One is labelled as **Assertion A** and the other is labelled as **Reason R**.

Assertion A: Two identical balls *A* and *B* thrown with same velocity '*u*' at two different angles with horizontal attained the same range *R*. If *A* and *B* reached the maximum height *h*₁ and *h*₂ respectively, then $R = 4\sqrt{h_1 h_2}$

Reason R: Product of said heights.

$$h_1 h_2 = \left(\frac{u^2 \sin^2 \theta}{2g} \right) \cdot \left(\frac{u^2 \cos^2 \theta}{2g} \right)$$

Question: Choose the correct answer :

- A Both **A** and **R** are true and **R** is the correct explanation of **A**.
 B Both **A** and **R** are true but **R** is NOT the correct explanation of **A**.
 C **A** is true but **R** is false.
 D **A** is false but **R** is true.

Ans. A

Sol.

$$R_1 = \frac{u^2 \sin 2\theta_1}{g} = R_2 = \frac{u^2 \sin 2\theta_2}{g}$$

$$H_1 = \frac{u^2 \sin^2 \theta_1}{2g} = H_2 = \frac{u^2 \cos^2 \theta_1}{2g}$$

$$H_1 H_2 = \frac{u^4 \sin^2 \theta \cos^2 \theta}{2^2 g^2}$$

- 2 Two buses *P* and *Q* start from a point at the same time and move in a straight line and their positions are represented by $X_P(t) = \alpha t + \beta t^2$ and $X_Q(t) = ft - t^2$. At what time, both the buses have same velocity ?

- A $\frac{\alpha - f}{1 + \beta}$
 B $\frac{\alpha + f}{2(\beta - 1)}$
 C $\frac{\alpha + f}{2(1 + \beta)}$
 D $\frac{f - \alpha}{2(1 + \beta)}$





Ans. D

Resonance Eduventures Ltd.

Reg. Office & Corp. Office : CG Tower, A-46 & 52, IPIA, Near City Mall, Jhalawar Road, Kota (Raj.) - 324005

Ph. No.: +91-744-2777777, 2777700 | FAX No. : +91-022-39167222

To Know more : sms RESO at 56677 | Website : www.resonance.ac.in | E-mail : contact@resonance.ac.in | CIN : U80302RJ2007PLC024029

Toll Free : 1800 258 5555  7340010333  facebook.com/ResonanceEdu  twitter.com/ResonanceEdu  www.youtube.com/resowatch  blog.resonance.ac.in

Sol.

$$V_P = \frac{dX_P}{dt} = \alpha + 2\beta t$$

$$V_Q = \frac{dX_Q}{dt} = f - 2t$$

so $V_P = V_Q$

$$\alpha + 2\beta t = f - 2t$$

$$t = \frac{f - \alpha}{2(1 + \beta)}$$

3

A disc with a flat small bottom beaker placed on it at a distance R from its center is revolving about an axis passing through the center and perpendicular to its plane with an angular velocity ω . The coefficient of static friction between the bottom of the beaker and the surface of the disc is μ . The beaker will revolve with the disc if :

A $R \leq \frac{\mu g}{2\omega^2}$

B $R \leq \frac{\mu g}{\omega^2}$

C $R \geq \frac{\mu g}{2\omega^2}$

D $R \geq \frac{\mu g}{\omega^2}$

Ans. B

Sol. From FBD

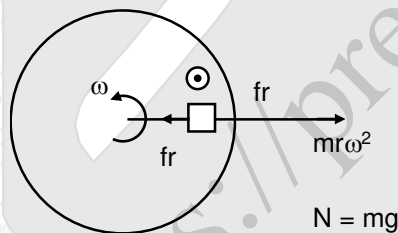

for circular motion

$$f = m\omega^2 r$$

$$\mu N \geq m\omega^2 r$$

$$\mu mg \geq m\omega^2 r$$

$$r \leq \frac{\mu g}{\omega^2}$$

Resonance Eduventures Ltd.

Reg. Office & Corp. Office : CG Tower, A-46 & 52, IPIA, Near City Mall, Jhalawar Road, Kota (Raj.) - 324005

Ph. No.: +91-744-2777777, 2777700 | FAX No. : +91-022-39167222

To Know more : sms RESO at 56677 | Website : www.resonance.ac.in | E-mail : contact@resonance.ac.in | CIN : U80302RJ2007PLC024029

Toll Free : 1800 258 5555 | 7340010333 | [facebook.com/ResonanceEdu](https://www.facebook.com/ResonanceEdu) | twitter.com/ResonanceEdu | www.youtube.com/resowatch | blog.resonance.ac.in

4 A solid metallic cube having total surface area 24 m^2 is uniformly heated. If its temperature is increased by 10°C , calculate the increase in volume of the cube. (Given $\alpha = 5.0 \times 10^{-4} \text{ }^\circ\text{C}^{-1}$).

A $2.4 \times 10^6 \text{ cm}^3$

B $1.2 \times 10^5 \text{ cm}^3$

C $6.0 \times 10^4 \text{ cm}^3$

D $4.8 \times 10^5 \text{ cm}^3$

Ans. B

Sol.

Given Total surface area $6l^2 = 24 \Rightarrow l = \sqrt{\frac{24}{6}} = 2\text{m}$

$\Delta V = V_0 \gamma \Delta\theta = l^3(3\alpha)\Delta\theta = 3 \times 2^3 \times 5 \times 10^{-4} \times 10 = 12 \times 10^{-2} \text{ m}^3 = 1.2 \times 10^5 \text{ cm}^3$

5 A copper block of mass 5.0 kg is heated to a temperature of 500°C and is placed on a large ice block. What is the maximum amount of ice that can melt? [Specific heat of copper : $0.39 \text{ J g}^{-1} \text{ }^\circ\text{C}^{-1}$ and latent heat of fusion of water : 335 J g^{-1}]

A 1.5 kg

B 5.8 kg

C 2.9 kg

D 3.8 kg

Ans. C

Sol. Heat given by block = heat received by ice.

M.S. $(T - 0) = M_{\text{ice}} \cdot L$





$\therefore M_{\text{ice}} = \frac{MST}{L} = \frac{5 \times 500 \times 0.39}{335} = 2.9 \text{ kg}$

Resonance Eduventures Ltd.

Reg. Office & Corp. Office : CG Tower, A-46 & 52, IPIA, Near City Mall, Jhalawar Road, Kota (Raj.) - 324005

Ph. No.: +91-744-2777777, 2777700 | FAX No. : +91-022-39167222

To Know more : sms RESO at 56677 | Website : www.resonance.ac.in | E-mail : contact@resonance.ac.in | CIN : U80302RJ2007PLC024029

Toll Free : 1800 258 5555  7340010333  facebook.com/ResonanceEdu  twitter.com/ResonanceEdu  www.youtube.com/resowatch  blog.resonance.ac.in

6

The ratio of specific heats $\left(\frac{C_P}{C_V}\right)$ in terms of degree of freedom (f) is given by :

A $\left(1 + \frac{f}{3}\right)$

B $\left(1 + \frac{2}{f}\right)$

C $\left(1 + \frac{f}{2}\right)$

D $\left(1 + \frac{1}{f}\right)$

Ans. B

7

For a particle in uniform circular motion, the acceleration \vec{a} at any point $P(R, \theta)$ on the circular path of radius R is (when θ is measured from the positive x -axis and v is uniform speed) :

A $-\frac{v^2}{R} \sin \theta \hat{i} + \frac{v^2}{R} \cos \theta \hat{j}$

B $-\frac{v^2}{R} \cos \theta \hat{i} + \frac{v^2}{R} \sin \theta \hat{j}$

C $-\frac{v^2}{R} \cos \theta \hat{i} - \frac{v^2}{R} \sin \theta \hat{j}$

D $-\frac{v^2}{R} \hat{i} + \frac{v^2}{R} \hat{j}$

Ans. C

Sol.

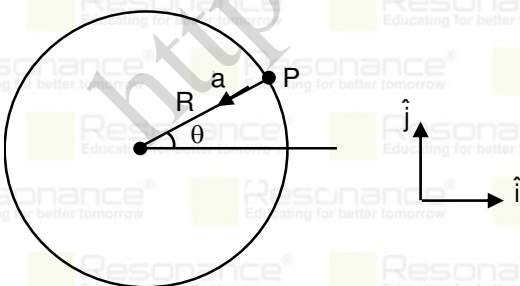

$$a = \frac{v^2}{R}$$

Resonance Eduventures Ltd.

Reg. Office & Corp. Office : CG Tower, A-46 & 52, IPIA, Near City Mall, Jhalawar Road, Kota (Raj.) - 324005

Ph. No.: +91-744-2777777, 2777700 | FAX No. : +91-022-39167222

To Know more : sms RESO at 56677 | Website : www.resonance.ac.in | E-mail : contact@resonance.ac.in | CIN : U80302RJ2007PLC024029

Toll Free : 1800 258 5555 | 7340010333 | [facebook.com/ResonanceEdu](https://www.facebook.com/ResonanceEdu) | twitter.com/ResonanceEdu | www.youtube.com/resowatch | blog.resonance.ac.in

$$\vec{a} = a \cos\theta(-\hat{i}) + a \sin\theta(-\hat{j})$$

$$-\frac{v^2}{R} \cos\theta \hat{i} - \frac{v^2}{R} \sin\theta \hat{j}$$

8 Two metallic plates form a parallel plate capacitor. The distance between the plate is 'd'. A metal sheet of thickness $\frac{d}{2}$ and of area equal to area of each plate is introduced between the plates. What will be the ratio of the new capacitance to the original capacitance of the capacitor?

A 2:1

B 1:2

C 1:4

D 4:1

Ans. A

Sol. Initial

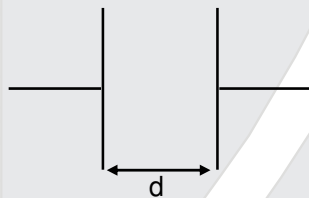

$$C = \frac{\epsilon_0 A}{d}$$

Final

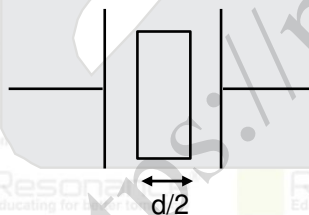

Final

$$C' = \frac{\epsilon_0 A}{d - d/2} = \frac{2 \epsilon_0 A}{d}$$

$$\frac{C'}{C} = 2$$

Resonance Eduventures Ltd.

Reg. Office & Corp. Office : CG Tower, A-46 & 52, IPIA, Near City Mall, Jhalawar Road, Kota (Raj.) - 324005

Ph. No.: +91-744-2777777, 2777700 | FAX No. : +91-022-39167222

To Know more : sms RESO at 56677 | Website : www.resonance.ac.in | E-mail : contact@resonance.ac.in | CIN : U80302RJ2007PLC024029

Toll Free : 1800 258 5555 | 7340010333 | [facebook.com/ResonanceEdu](https://www.facebook.com/ResonanceEdu) | twitter.com/ResonanceEdu | www.youtube.com/resowatch | blog.resonance.ac.in

9 Two cells of same emf but different internal resistances r_1 and r_2 are connected in series with a resistance R . The value of resistance R , for which the potential difference across second cell is zero, is :

- A $r_2 - r_1$
- B $r_1 - r_2$
- C r_1
- D r_2

Ans. A

Sol.

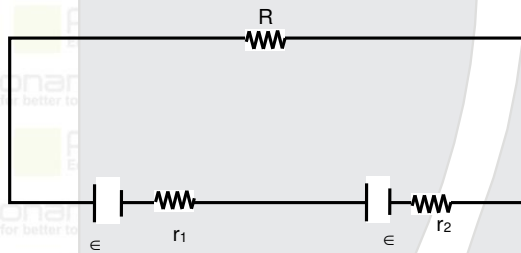

$$i = \frac{2\epsilon}{r_1 + r_2 + R}$$

$$\Delta V_2 = \epsilon - ir_2 = 0$$

$$\epsilon = \frac{2\epsilon}{r_1 + r_2 + R} \times r_2$$

$$R = r_2 - r_1$$

10 Given below are two statements :

Statement – I : Susceptibilities of paramagnetic and ferromagnetic substances increase with decrease in temperature.

Statement – II : Diamagnetism is a result of orbital motions of electrons developing magnetic moments opposite to the applied magnetic field.

Choose the correct answer from the options given below :-

- A Both Statement – I and Statement – II are true.
- B Both Statement – I and Statement – II are false.
- C Statement – I is true but Statement – II is false.
- D Statement – I is false but Statement – II is true.

Ans. A

Resonance Eduventures Ltd.

Reg. Office & Corp. Office : CG Tower, A-46 & 52, IPIA, Near City Mall, Jhalawar Road, Kota (Raj.) - 324005

Ph. No.: +91-744-2777777, 2777700 | FAX No. : +91-022-39167222

To Know more : sms RESO at 56677 | Website : www.resonance.ac.in | E-mail : contact@resonance.ac.in | CIN : U80302RJ2007PLC024029

Toll Free : 1800 258 5555 7340010333 facebook.com/ResonanceEdu twitter.com/ResonanceEdu www.youtube.com/resowatch blog.resonance.ac.in

11 A long solenoid carrying a current produces a magnetic field B along its axis. If the current is doubled and the number of turns per cm is halved, the new value of magnetic field will be equal to

- A B
- B $2B$
- C $4B$
- D $\frac{B}{2}$

Ans. A

Sol. $B = \mu_0 \left(\frac{N}{\ell} \right) I$ (i)

$N' = \frac{N}{2}$ $I' = 2I$

$B' = \mu_0 \left(\frac{N/2}{\ell} \right) \cdot 2I$; $B' = B$.

12 A sinusoidal voltage $V(t) = 210 \sin 3000 t$ volt is applied to a series LCR circuit in which $L = 10 \text{ mH}$, $C = 25 \mu\text{F}$ and $R = 100 \Omega$. The phase difference (Φ) between the applied voltage and resultant current will be :

- A $\tan^{-1}(0.17)$
- B $\tan^{-1}(9.46)$
- C $\tan^{-1}(0.30)$
- D $\tan^{-1}(13.33)$

Ans. A

Sol. $X_C = \frac{1}{\omega C} = \frac{1}{3000 \times 25 \times 10^{-6}} = \frac{40}{3} \Omega$

$X_L = \omega L = 3000 \times 10 \times 10^{-3} = 30 \Omega$

$X = X_L - X_C$
 $= 30 - \frac{40}{3} = \frac{50}{3} \Omega$

$\tan \phi = \frac{X}{R} = \frac{50/3}{100} = \frac{1}{6}$

$\tan \phi = \frac{1}{6} = 0.17$

Resonance Eduventures Ltd.

Reg. Office & Corp. Office : CG Tower, A-46 & 52, IPIA, Near City Mall, Jhalawar Road, Kota (Raj.) - 324005

Ph. No.: +91-744-2777777, 2777700 | FAX No. : +91-022-39167222

To Know more : sms RESO at 56677 | Website : www.resonance.ac.in | E-mail : contact@resonance.ac.in | CIN : U80302RJ2007PLC024029

Toll Free : 1800 258 5555  7340010333  facebook.com/ResonanceEdu  twitter.com/ResonanceEdu  www.youtube.com/resowatch  blog.resonance.ac.in

13 The electromagnetic waves travel in a medium at a speed of 2.0×10^8 m/s. The relative permeability of the medium is 1.0. The relative permittivity of the medium will be :

- A 2.25
 B 4.25
 C 6.25
 D 8.25

Ans. A

Sol.
$$\frac{1}{\sqrt{\mu_r \epsilon_r}} = 2 \times 10^8 = \frac{1}{\sqrt{\mu_r \epsilon_r} \sqrt{\mu_0 \epsilon_0}} = \frac{3 \times 10^8}{\sqrt{\epsilon_r}}$$

$$\epsilon_r = 9/4$$

14 The interference pattern is obtained with two coherent light sources of intensity ratio 4:1. And the ratio $\frac{I_{\max} + I_{\min}}{I_{\max} - I_{\min}}$ is $\frac{5}{x}$. Then, the value of x will be equal to :

- A 3
 B 4
 C 2
 D 1

Ans. B

Sol.
$$\frac{I_1}{I_2} = \frac{4}{1} \Rightarrow \frac{A_1}{A_2} = \frac{2}{1}$$

$$\frac{(A)_{\max}}{(A)_{\min}} = \frac{2+1}{2-1} = \frac{3}{1}$$

$$\frac{(I)_{\max}}{(I)_{\min}} = \left(\frac{3}{1}\right)^2 = \frac{9}{1}$$





$$\frac{(I)_{\max} + (I)_{\min}}{(I)_{\max} - (I)_{\min}} = \frac{9+1}{9-1} = \frac{10}{8} = \frac{5}{4}$$
 So, $x = 4$

Resonance Eduventures Ltd.

Reg. Office & Corp. Office : CG Tower, A-46 & 52, IPIA, Near City Mall, Jhalawar Road, Kota (Raj.) - 324005

Ph. No.: +91-744-2777777, 2777700 | FAX No. : +91-022-39167222

To Know more : sms RESO at 56677 | Website : www.resonance.ac.in | E-mail : contact@resonance.ac.in | CIN : U80302RJ2007PLC024029

Toll Free : 1800 258 5555  7340010333  facebook.com/ResonanceEdu  twitter.com/ResonanceEdu  www.youtube.com/resowatch  blog.resonance.ac.in

- 15 A light whose electric field vectors are completely removed by using a good polaroid, allowed to incident on the surface of the prism at Brewster's angle. Choose the most suitable option for the phenomenon related to the prism.
- A Reflected and refracted rays will be perpendicular to each other.
- B Wave will propagate along the surface of prism.
- C No refraction, and there will be total reflection of light.
- D No reflection, and there will be total transmission of light.

Ans. D

- 16 A proton, a neutron, an electron and an α -particle have same energy. If λ_p , λ_n , λ_e and λ_α are the de Broglie's wavelengths of proton, neutron, electron and α particle respectively, then choose the correct relation from the following :

- A $\lambda_p = \lambda_n > \lambda_e > \lambda_\alpha$
- B $\lambda_\alpha < \lambda_n < \lambda_p < \lambda_e$
- C $\lambda_e < \lambda_p = \lambda_n > \lambda_\alpha$
- D $\lambda_e = \lambda_p = \lambda_n = \lambda_\alpha$

Ans. B

Sol. $\lambda = \frac{h}{\sqrt{2mE}}$

$$\lambda \propto \frac{1}{\sqrt{m}}$$

Let mass of electron = m_e

Let mass of Proton = m

Let mass of Neutron = $2m$

Let mass of α particle = $4m$





and $m_e < m$

Resonance Eduventures Ltd.

Reg. Office & Corp. Office : CG Tower, A-46 & 52, IPIA, Near City Mall, Jhalawar Road, Kota (Raj.) - 324005

Ph. No.: +91-744-2777777, 2777700 | FAX No. : +91-022-39167222

To Know more : sms RESO at 56677 | Website : www.resonance.ac.in | E-mail : contact@resonance.ac.in | CIN : U80302RJ2007PLC024029

Toll Free : 1800 258 5555  7340010333  facebook.com/ResonanceEdu  twitter.com/ResonanceEdu  www.youtube.com/resowatch  blog.resonance.ac.in

17

Which of the following figure represents the variation of $\ln \left(\frac{R}{R_0} \right)$ with $\ln A$ (if $R =$ radius of a nucleus and $A =$ its mass number)

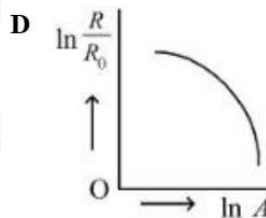
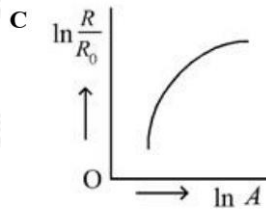
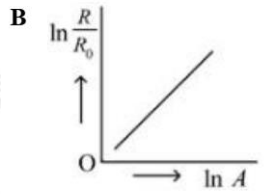
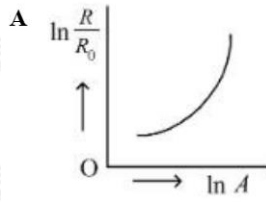

Ans. B

Sol. $R = R_0 A^{1/3}$

$$\frac{R}{R_0} = A^{1/3} \Rightarrow \log \left(\frac{R}{R_0} \right) = \frac{1}{3} \log(A)$$

$$y = mx$$

$$\text{slope} = \frac{1}{3}$$

Resonance Eduventures Ltd.

Reg. Office & Corp. Office : CG Tower, A-46 & 52, IPIA, Near City Mall, Jhalawar Road, Kota (Raj.) - 324005

Ph. No.: +91-744-2777777, 2777700 | FAX No. : +91-022-39167222

To Know more : sms RESO at 56677 | Website : www.resonance.ac.in | E-mail : contact@resonance.ac.in | CIN : U80302RJ2007PLC024029

Toll Free : 1800 258 5555 | WhatsApp : 7340010333 | Facebook : facebook.com/ResonanceEdu | Twitter : twitter.com/ResonanceEdu | YouTube : www.youtube.com/resowatch | Blog : blog.resonance.ac.in

18 Identify the logic operation performed by the given circuit :

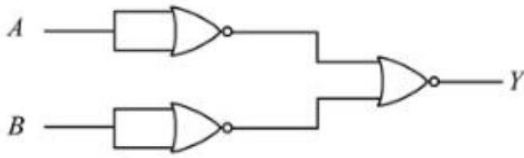

- A AND gate
- B OR gate
- C NOR gate
- D NAND gate

Ans. A

Sol.

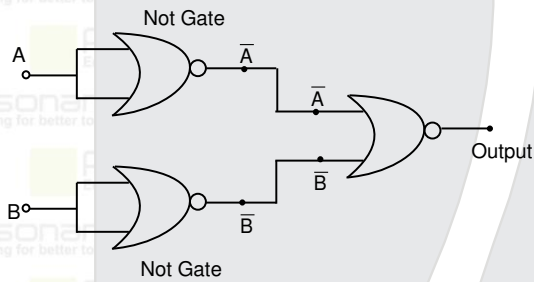

$$\begin{aligned} \text{Output} &= \overline{A} + \overline{B} \\ &= \overline{A \cdot B} \\ &= A \cdot B \end{aligned}$$

19 Match List I with List II

List I

- A. Facsimile
- B. Guided media Channel
- C. Frequency Modulation
- D. Digital Signal

List II

- I. Static Document Image
- II. Local Broadcast Radio
- III. Rectangular wave
- IV. Optical Fiber

Choose the correct answer from the following options :

- A A-IV, B-III, C-II, D-I
- B A-I, B-IV, C-II, D-III
- C A-IV, B-II, C-III, D-I
- D A-I, B-II, C-III, D-IV

Ans. B

Resonance Eduventures Ltd.

Reg. Office & Corp. Office : CG Tower, A-46 & 52, IPIA, Near City Mall, Jhalawar Road, Kota (Raj.) - 324005

Ph. No.: +91-744-2777777, 2777700 | FAX No. : +91-022-39167222

To Know more : sms RESO at 56677 | Website : www.resonance.ac.in | E-mail : contact@resonance.ac.in | CIN : U80302RJ2007PLC024029

Toll Free : 1800 258 5555 7340010333 facebook.com/ResonanceEdu twitter.com/ResonanceEdu www.youtube.com/resowatch blog.resonance.ac.in

20 If n represents the actual number of deflections in a converted galvanometer of resistance G and shunt resistance S . Then the total current I when its figure of merit is K will be :

A $\frac{KS}{(S+G)}$

B $\frac{(G+S)}{nKS}$

C $\frac{nKS}{(G+S)}$

D $\frac{nK(G+S)}{S}$

Ans. D

Sol.

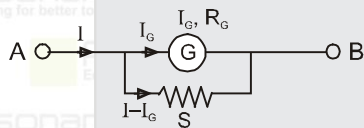

Given figure of merit $K = \frac{I_g}{n}$

$$I = \frac{I_g(R_g + s)}{s}$$

$$I = \frac{nk(G + s)}{s}$$

21

For $z = a^2x^3y^{\frac{1}{2}}$, where 'a' is a constant. If percentage error in measurement of 'x' and 'y' are 4% and 12%, respectively, then the percentage error for 'z' will be _____ %.

Ans. 18.00

Sol. $R = a^2x^3y^{1/2}$

$$\left| \frac{\Delta R}{R} \right|_{\max} \times 100 = 3 \left(\frac{\Delta x}{x} \times 100 \right) + \frac{1}{2} \left(\frac{\Delta y}{y} \right) \times 100$$

$$= 3.(4) + \frac{1}{2} \times (12)$$

$$= 12 + 6 = 18\%$$

22

A curved in a level road has a radius 75 m. The maximum speed of a car turning this curved road can be 30 m/s without skidding. If radius of curved road is changed to 48 m and the coefficient of friction between the tyres and the road remains same, then maximum allowed speed would be _____ m/s.

Ans. 24.00

Resonance Eduventures Ltd.

Reg. Office & Corp. Office : CG Tower, A-46 & 52, IPIA, Near City Mall, Jhalawar Road, Kota (Raj.) - 324005

Ph. No.: +91-744-2777777, 2777700 | FAX No. : +91-022-39167222

To Know more : sms RESO at 56677 | Website : www.resonance.ac.in | E-mail : contact@resonance.ac.in | CIN : U80302RJ2007PLC024029

Toll Free : 1800 258 5555 7340010333 facebook.com/ResonanceEdu twitter.com/ResonanceEdu www.youtube.com/resowatch blog.resonance.ac.in

Sol. $\tan \theta = \frac{v^2}{Rg}$, then $v \propto \sqrt{r}$

$$\frac{v_2}{v_1} = \frac{\sqrt{r_2}}{\sqrt{r_1}} = \sqrt{\frac{48}{75}}$$

$$v_2 = \frac{4}{5} \times 30 = 24 \text{ m/s}$$

- 23 A block of mass 200 g is kept stationary on a smooth inclined plane by applying a minimum horizontal force $F = \sqrt{x}N$ as shown in figure.

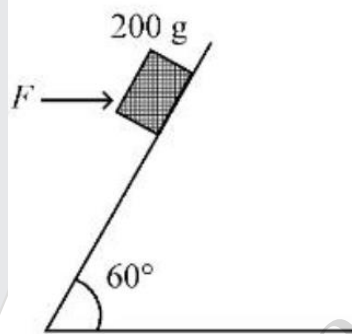

The value of $x =$ _____.

Ans. 12.00

Sol.

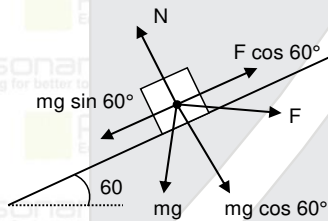

A long surface

$$F \cos 60^\circ = mg \sin 60^\circ$$

$$F = mg \tan 60^\circ$$

$$= 200 \times 10 \times \sqrt{3} \times 10^{-3} = 2\sqrt{3} = \sqrt{12} \text{ N}$$

Resonance Eduventures Ltd.

Reg. Office & Corp. Office : CG Tower, A-46 & 52, IPIA, Near City Mall, Jhalawar Road, Kota (Raj.) - 324005

Ph. No.: +91-744-2777777, 2777700 | FAX No. : +91-022-39167222

To Know more : sms RESO at 56677 | Website : www.resonance.ac.in | E-mail : contact@resonance.ac.in | CIN : U80302RJ2007PLC024029

Toll Free : 1800 258 5555 7340010333 facebook.com/ResonanceEdu twitter.com/ResonanceEdu www.youtube.com/resowatch blog.resonance.ac.in

24 Moment of Inertia (M.I.) of four bodies having same mass ' M ' and radius ' $2R$ ' are as follows :

I_1 = M.I. of solid sphere about its diameter

I_2 = M.I. of solid cylinder about its axis

I_3 = M.I. of solid circular disc about its diameter

I_4 = M.I. of thin circular ring about its diameter

If $2(I_2 + I_3) + I_4 = x \cdot I_1$ then the value of x will be _____.

Ans. 05.00

Sol. $2(I_2 + I_3) + I_4 = x \cdot I_1$

$$2 \left[\frac{MR^2}{2} + \frac{MR^2}{4} \right] + \frac{MR^2}{2} = x \left[\frac{2}{5} MR^2 \right]$$

$$2MR^2 = x \left[\frac{2}{5} MR^2 \right]$$

$$x = 5$$

25 Two satellites S_1 and S_2 are revolving in circular orbits around a planet with radius $R_1 = 3200 \text{ km}$ and $R_2 = 800 \text{ km}$ respectively. The ratio of speed of satellite S_1 to the speed of satellite S_2 in their respective orbits would be $\frac{1}{x}$ where $x =$

Ans. 02.00

Sol. $V \propto \frac{1}{\sqrt{R}}$

$$\frac{V_1}{V_2} = \sqrt{\frac{R_2}{R_1}} = \sqrt{\frac{800}{3200}} = \frac{1}{2}$$

26 When a gas filled in a closed vessel is heated by raising the temperature by 1°C , its pressure increases by 0.4%. The initial temperature of the gas is _____ K.

Ans. 250

Sol. Given $\Delta T = 1, \Delta P = 0.4\%$

$P \propto T$

$$\frac{\Delta P}{P} = \frac{\Delta T}{T}$$

$$0.4 = \frac{1 \times 100}{T}$$

$$T = 250$$

Resonance Eduventures Ltd.

Reg. Office & Corp. Office : CG Tower, A-46 & 52, IPIA, Near City Mall, Jhalawar Road, Kota (Raj.) - 324005

Ph. No.: +91-744-2777777, 2777700 | FAX No. : +91-022-39167222

To Know more : sms RESO at 56677 | Website : www.resonance.ac.in | E-mail : contact@resonance.ac.in | CIN : U80302RJ2007PLC024029

Toll Free : 1800 258 5555 | 7340010333 | [facebook.com/ResonanceEdu](https://www.facebook.com/ResonanceEdu) | twitter.com/ResonanceEdu | www.youtube.com/resowatch | blog.resonance.ac.in

27 27 identical drops are charged at $22V$ each. They combine to form a bigger drop. The potential of the bigger drop will be _____ V .

Ans. 198

Sol.



$$R = (27)^{1/3} r = 3r$$

$$V = \frac{KQ}{R} = \frac{K(27q)}{3r} = 9 \times v = 9 \times 22 = 198 \text{ Volt}$$

28 The length of a given cylindrical wire is increased to double of its original length. The percentage increase in the resistance of the wire will be _____ %.

Ans. 300

Sol.



$$R' = n^2 R$$

$$R' = 4R$$

$$\% \text{ change} = \left(\frac{R' - R}{R} \right) \times 100 = \left(\frac{4R - R}{R} \right) \times 100 = 300\%$$

29 In a series LCR circuit, the inductance, capacitance and resistance are $L = 100 \text{ mH}$, $C = 100 \mu F$ and $R = 10 \Omega$ respectively. They are connected to an AC source of voltage $220 V$ and frequency of 50 Hz . The approximate value of current in the circuit will be _____ A .

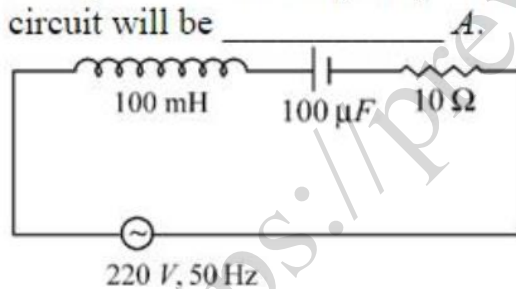

Ans. 22.00

Sol.

$$X_C = \frac{1}{\omega C} = \frac{1}{2\pi \times 50 \times 100 \times 10^{-6}} = \frac{100}{\pi} = 10\pi \Omega$$

$$X_L = \omega L = 2\pi \times 50 \times 100 \times 10^{-3} = 10\pi \Omega$$

$$X = X_C - X_L = 10\pi - 10\pi = 0$$

$$\text{Current} = i = \frac{V}{Z} = \frac{V}{\sqrt{R^2 + X^2}} = \frac{220}{10} = 22A$$

Resonance Eduventures Ltd.

Reg. Office & Corp. Office : CG Tower, A-46 & 52, IPIA, Near City Mall, Jhalawar Road, Kota (Raj.) - 324005

Ph. No.: +91-744-2777777, 2777700 | FAX No. : +91-022-39167222

To Know more : sms RESO at 56677 | Website : www.resonance.ac.in | E-mail : contact@resonance.ac.in | CIN : U80302RJ2007PLC024029

Toll Free : 1800 258 5555 | 7340010333 | [facebook.com/ResonanceEdu](https://www.facebook.com/ResonanceEdu) | twitter.com/ResonanceEdu | www.youtube.com/resowatch | blog.resonance.ac.in

30 In an experiment of CE configuration of n-p-n transistor, the transfer characteristics are observed as given in figure.

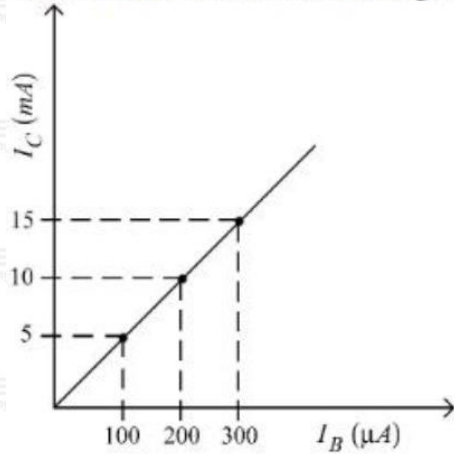

If the input resistance is 200Ω and output resistance is 60Ω , the voltage gain in this experiment will be _____.

Ans. 15.00

Sol.

$$\beta_{AC} = \frac{\Delta i_c}{\Delta i_B} = \frac{5 \times 10^{-3}}{100 \times 10^{-6}} = 50$$



$$A_v = \beta_{AC} \times \frac{R_{out}}{R_{in}} = (50) \left(\frac{60}{200} \right) = 15$$

Resonance Eduventures Ltd.

Reg. Office & Corp. Office : CG Tower, A-46 & 52, IPIA, Near City Mall, Jhalawar Road, Kota (Raj.) - 324005

Ph. No.: +91-744-2777777, 2777700 | FAX No. : +91-022-39167222

To Know more : sms RESO at 56677 | Website : www.resonance.ac.in | E-mail : contact@resonance.ac.in | CIN : U80302RJ2007PLC024029

Toll Free : 1800 258 5555  7340010333  facebook.com/ResonanceEdu  twitter.com/ResonanceEdu  www.youtube.com/resowatch  blog.resonance.ac.in

Numbers that Inspire Students to **EXCEL**

Trust of 9,50,000+ STUDENTS*	Total Selections 1,78,546 <small>JEE (Adv.) + Eligibility for JEE (Main) + NEET (UG)</small>	AIRs in TOP-100 350 <small>JEE (Adv.) + JEE (Main) + NEET (UG)</small>	Pool of 800+ FACULTY	Study Centres in 70+ CITIES
---	---	--	-----------------------------------	--

*Since 2001 | **Students Qualified from JEE (Main) to JEE (Advanced) since 2012 | Top 50 (lectures & AIRs in TOP-100 mentioned are in JEE (Adv.) | JEE (Main) since 2002, JEE (Main) / APJEE (since 2009), NEET (UG) / APJEE (since 2012) | APJEE (Kota Park)

The 10-Building Blocks of **Proven & Trusted Teaching Methodology @ Resonance**

Success is Assured when you Do*

200 X Practice | 20 X Testing

1500+ Hrs. Classroom Teaching	10000+ Pages Study Material
45000+ Questions Practice Problems	50+ Tests 200+ Hrs. Testing & Assessment

*As per Latest Pattern of JEE (Main) & JEE (Advanced)

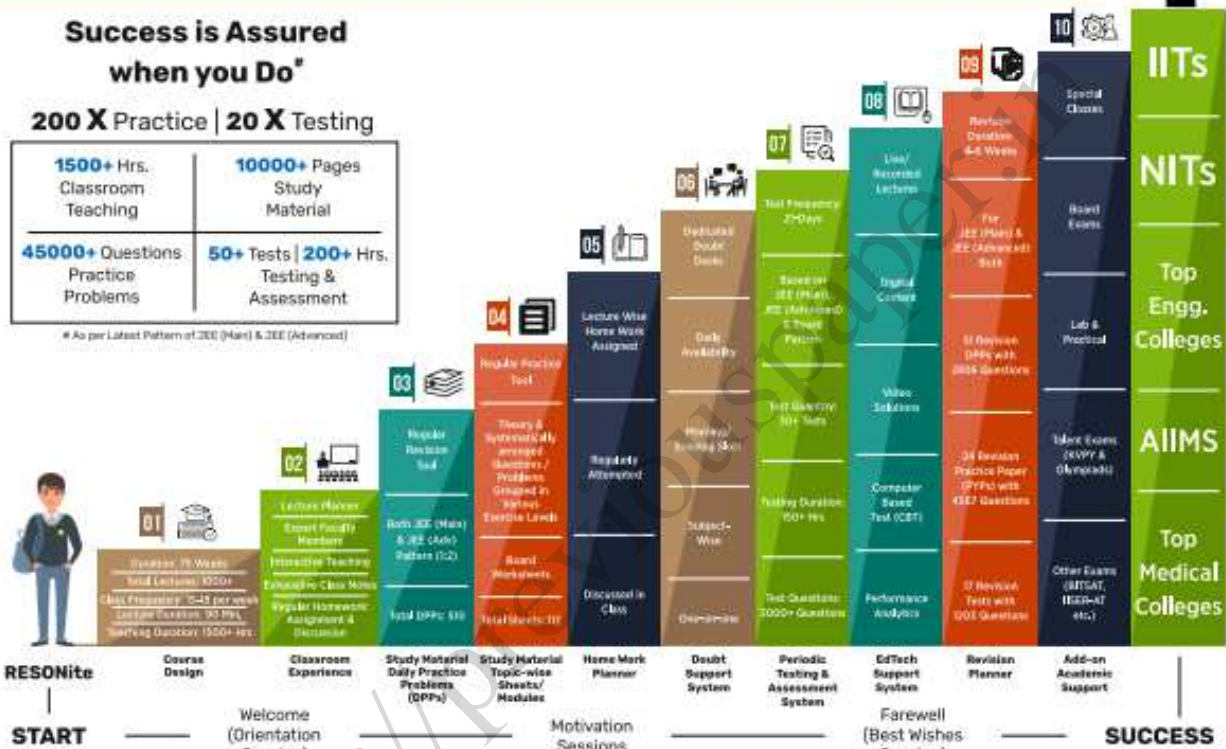

The figures (approx.) shown in the graph are of 2 Years Classroom Program (VIKAAS-XI & VIETA-XII) for JEE (Advanced) @ Resonance in Academic Session 2021-22. The figures vary for JEE (Main), NEET (UG) and Other Courses.

The Strong Faculty Team at Resonance Kota to deliver this successful Teaching Methodology



SCHOLARSHIP UPTO

100%

Based on JEE (Main) 2022 NTA Score (Percentile) & Scholarship Test (ResoNET)

Admission Announcement: 2022-23 Class: 5 to 12 & 12+

ResoNET 3rd & 10th July

Target: JEE (Advanced) | JEE (Main) | NEET (UG) Pre-Foundation (V to X) | Board

Polish your subject knowledge to Shine in JEE (Advanced) 2022 with the guidance of HODs & Top Notch Sr. Faculty of Resonance

SPARK 7 WEEKS COMPACT COURSE OFFLINE/ONLINE

from 4th July 2022

Scholarship upto 90%

Resonance Eduventures Ltd.

Follow us at

Kota Study Centre & Registered Corporate Office:
CG Tower, A-46 & 52, IPIA, Near City Mall,
Jhalawar Road, Kota (Raj.) - 324005

Tel No.: 0744-2777777, 2777700

Toll Free: 1800 258 5555 | CIN: U80302RJ2007PLC024029

e-mail: contact@resonance.ac.in | visit: www.resonance.ac.in